



YOUR PARTNER IN METALWORKING

# MG ITALY PRODUCTS e MACHINERY 2023

“Teamwork is the ability to work together toward a common vision. The ability to direct individual accomplishments toward organizational objectives”. (A.Carnegie)

[mgitaly.it](http://mgitaly.it)

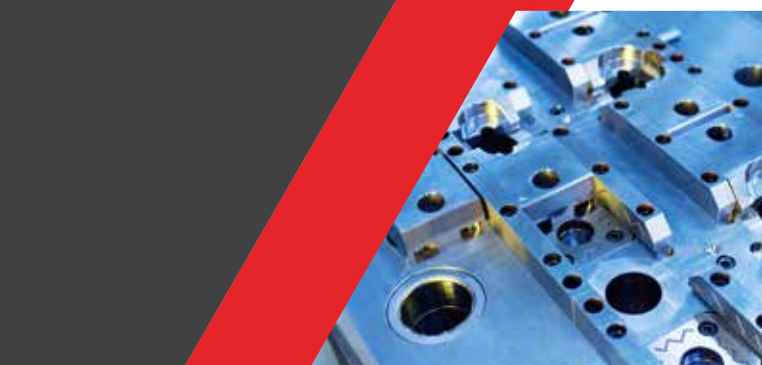

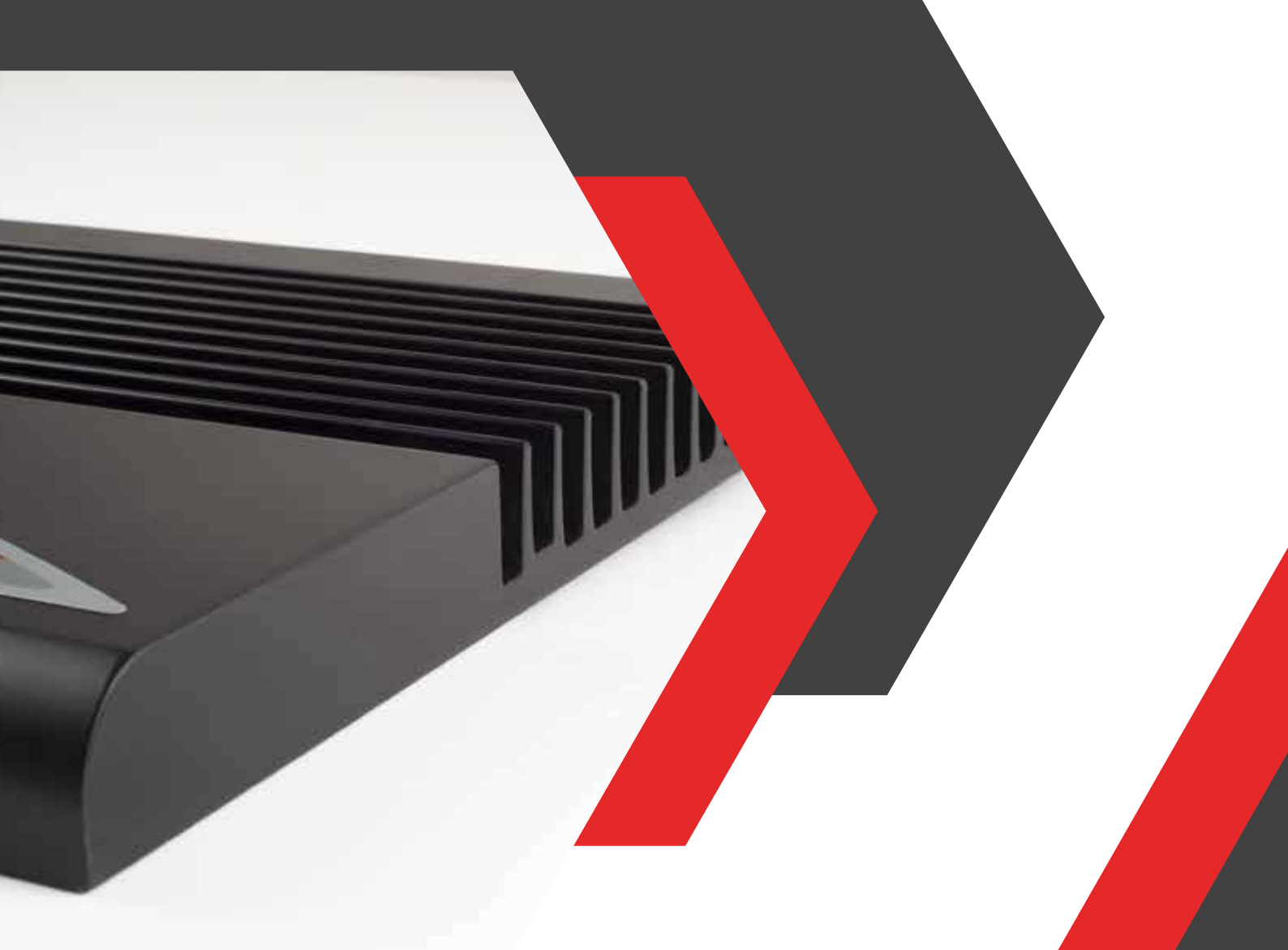

**MG ITALY**

YOUR PARTNER IN METALWORKING

MG philosophy:

***“Competition is not about what  
companies produce, but about what  
they are able to add to the product”***



# Index

Company, Mission & Vision	P.	04
Company Quality, Experience & Expertise	P.	05
Company Profile, Structure & Partnership	P.	06 - 07
Business Unit	P.	08 - 11
Extruded technology	P.	13 - 40
Welded technology	P.	41 - 47
Assembled technology	P.	48 - 61
"HEATPLUS" technology	P.	62 - 67
ColdPlate technology	P.	68 - 69
Dissipation technology MGSKIVED	P.	70 - 71
PV fasteners	P.	72 - 84
Processes – Machining	P.	85 - 87



YOUR PARTNER IN METALWORKING

**Leading group in mechanical machining and automation worldwide. Over the years, our group has remained fully committed to being a top-level manufacturer in high-precision machining and high-quality electromechanical components.**



**100 +**  
Employees



**3**  
Production plants

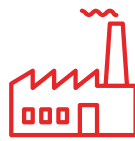

**4.00 Sqm**  
Surface



**25**  
Production lines

MG develops and produces heat dissipation systems with different technologies, air, liquid, and many others. Our organization is engaged in different sectors: Continuous Facades, Furniture, Transportation, Cooling Company, Automotive, Electronics, Civil and Military Defence, Design Lighting, Motors, Aerospace, Photovoltaic, many others.

Our group today covers an area of 4,000 square meters with over 100 operators and employees and operates in the sector of precision machining for industries of various sectors making use of constantly updated infrastructures and production plants.



## Mission e vision

Teamwork is the ability to work together toward a common vision.

The ability to direct individual accomplishments toward organizational objectives.



# Experience and Expertise

## *Technical expertise at the service of our customer*

Our technical staff, thanks to their considerable experience, will be able to deal reactively and with excellent quality and innovative solutions for any of your needs.

A unique service that has allowed us, over the years, to attract the attention of companies on a global level as well.

UNI EN ISO 9001:2015



## Company Quality

### *Our organization is in continuous development, in a continuous search to improve each of its processes.*

Our Top Management is continuously and systematically involved in the implementation, maintenance, development and improvement of the Quality Management System.

In Quality Management System (QMS) which allows to guarantee the achievement of the set objectives and customer satisfaction, in compliance with the applicable reference Standards and Directives, as well as with the specific contractual requirements.



## OUR BASIC PRINCIPLES

- ✓ *Satisfaction and focus on customer needs*
- ✓ *Always improving products and services offered*
- ✓ *Compliance with the requirements specified by customers*
- ✓ *Compliance with ASD customer requirements*
- ✓ *Compliance with workplace safety regulations*
- ✓ *High healthy and safety standards and regulations*
- ✓ *ISO 9001 QMS*
- ✓ *International Management System*

# COMPANY PROFILE

In 40 years we have developed an extraordinary set of skills accompanied by the typical commitment of those who want to be leaders and always placing the customer and their needs at the center of their business decisions, we have worked hard to obtain gratifying results both professionally and socially with particular regard to environmental protection.

On these premises, the company management has invested considerable energy to instill a new corporate culture understood as a consolidated and widespread practice in all sectors of the company. An ethical culture whose fundamental pillars are found in the values that have always distinguished our Company.



## Company Structure

- ✓ Technical ability of operators to identify customer problems
- ✓ Many years of knowledge based on continuous technical updating and on maintaining high quality standards
- ✓ International team, English, German, Spanish and Russian native speakers
- ✓ Technical personnel with a notable and consolidated background gained through multiple and heterogeneous experiences in diversified sectors
- ✓ Carefully selected suppliers, according to a production chain system

# International partners, we are present in foreign markets

We have many years of knowledge based on continuous technical updating and on maintaining high quality standards in order to ensure high corporate competitiveness. The company management has thought of a flexible and adequate structure built according to the suggestions of the customers to better assist them.

- 1** **Spain**  
Aerospace, Furniture, Nautical
- 2** **USA**  
Dissipation, Electric Mobility
- 3** **Germany**  
Aerospace, Electronics, Automotive
- 4** **Slovakia**  
Industry, Electronics, Renewable Energy
- 5** **Italy**  
Industry, Electronics, Renewable Energy



# Business Unit

---

Our main strength is our highly qualified personnel who, having the latest generation machinery, the result of constant investments, are able to achieve increasingly stringent quality standards.

The continuous refinement of production technologies, combined with the experience gained in more than forty years of mechanical machining, makes the company the ideal partner for customers operating in different application sectors.

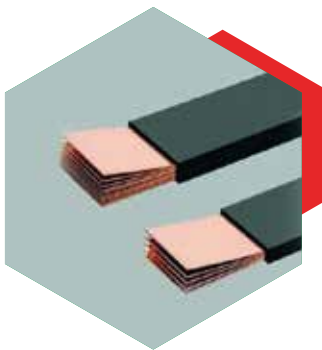

## Business Unit: **BusBars e Connections**

---

### **FLEXIBLE BUSBARS**

Round, tubular and flat copper braids are an extra flexible conductor for all electrical connection needs, including power, earth and equipotential connections.

The new copper-insulated flexible bar, produced in a new and advanced production plant, is the only flexible bar and stands out, through the innovative features, for its high flexibility, excellent appearance and easy use.

The “barrel” insulator is used as an insulating support for active conductors, a support for electrical equipment, a spacer and/or stiffening element of a system made up of conductor bars (in copper and/or aluminium).

### **RIGID BUSBARS**

In our Electronics division, we make all the connection components in copper and not only. The materials are chosen according to the needs each project.

We have various busbar solutions, which are designed together with our customers. Each project is created according to your needs.



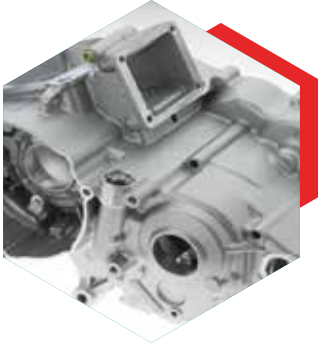

## Business Unit: **DIE CASTING**

---

We operate in the aluminum die-casting sector and thanks to the great experience accumulated over the last few decades, we offer a complete service, from the creation of the mold to the supply of the machined and tested piece.

We are able to collect all the requests from our customers, having the possibility of carrying out mechanical machining on die-cast parts, as well as performing aesthetic finishes.

Often, the customer prefers to commission the finishing activity, both to speed up the timing of the process and to have a single contact person and therefore not having to personally follow each phase.

Our Company is able to supply die-casting of any type of aluminum alloy.

In addition to the most used alloys (EN AB-43400, EN AB- 44300, EN AB-46000, EN AB-46100, EN AB-47100), we can use special alloys such as Silafont 36. All the molten aluminum in the central melting furnaces is then subjected to a degassing and slagging treatment with nitrogen and salts.



## Business Unit: **METAL PLATES**

---

### **3 fiber laser systems with automatic loading and unloading and 2 punching machines:**

- 1 Amada LCG-AJ 6KW laser cutting machine with automated warehouse
- 1 Amada ENSIS 3015 AJ 2KW laser cutting machine with automated warehouse
- 1 Trumpf TruLaser 5030 fiber (L76) laser cutting machine with automated warehouse
- 1 Trumpf 3000 punching machine with bar loading and unloading bench
- 1 Rainer punching machine

### **Bending:**

- 6 bending press brakes
- 1 automatic panel bender with flag bending system
- 1 HG ATC ARS Amada robotic bending cell
- 1 Starmatick robotic bending cell

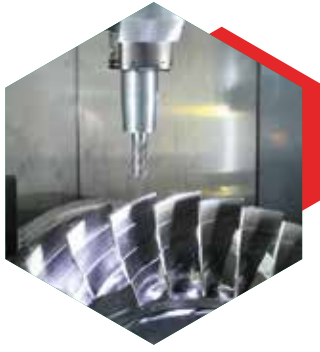

## Business Unit: **INDUSTRIES**

---

This division deals with mechanical machining on CNC Milling and Turning centers, based on the executive drawings provided by our customers or by our technical office.

The machinery present in our production lines are all of the latest generation and constantly updated to guarantee high-performance and competitive processes on the market.

The entire production process is monitored through our operational processes that allow you to have quality and timing control on all productions.

Further information can be found on our website [www.mgitaly.it](http://www.mgitaly.it)

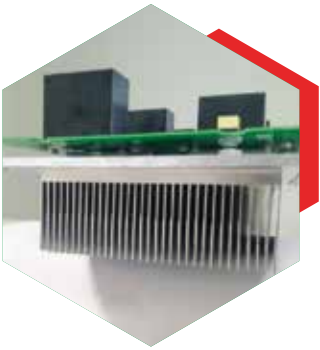

## Business Unit: **ELECTRONICS**

---

### **EXTRUDED**

We are one of the world's leading manufacturers of aluminum heat sinks. Our main activities include the study, design and development of profiles aimed at the creation of finished products.

Innovative and flexible, we are able to provide customized solutions for any type of application. We produce extruded heat sinks, assembled, according to the requests of our customers.

We have been developing new ideas for over 40 years and our product range includes more than a thousand extruded aluminum profiles and more than 20,000 finished products. You can find out more about these aspects on our website: [www.mgitaly.it](http://www.mgitaly.it)

---

### **Cold\_Plate**

The COLD\_PLATE solution is the optimal solution for efficiently managing complex systems with high concentrated powers. Water cooling is thus becoming the ideal alternative for dissipating high powers. This system avoids noise and problems due to vibrations, considering that this dissipation system can also be used in dusty environments where forced air cannot be used.



## Business Unit: **WELDINGS**

Laser, tig, mig/mag and a dedicated robot for high quality welding services.

- 1 Welding Robot
- TIG & MIG welding machines



## Business Unit: **Plastic materials**

### **Plastic materials for electrical insulators and mechanical components**

Once in operation, every plant requires a powerful and reliable electrical system. Generators, transformers and switchboards must always be coordinated with the expected performance and structure of the installation. We help you in the construction with our thermosetting semi-finished products, which have been used in the electrical industry all over the world for over 40 years. Highly resistant to electrical, mechanical and thermal loads, with our materials you develop generators, transformers and switchboards with high operational safety.

#### **Your benefits**

High operational safety - Long duration - Low flammability - High electrical stability - High mechanical stability - High thermal resistance

#### **Application**

Electrical systems High power systems Energy cooling systems, UPS, Systems with high operating temperatures.

#### **Used materials:**

Gpo3  
Pvc  
Lexan  
Vetronite



Business Unit:  
**MILLING**

---

With a fleet of over 15 high-level machining centres, MG proposes itself as prime contractor for carrying out mechanical machining to customer drawings, in order to guarantee the production of high precision parts with limited time and cost.

All CNC machines are always manned by assigned personnel who are exclusively responsible for the good execution and dimensional control of the product they are making.

To make this way of working possible, the department heads supervise the production cycle, while other qualified personnel carry out some necessary and fundamental operations.

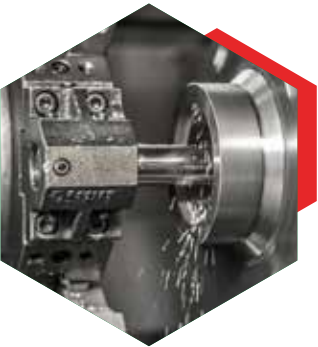

Business Unit:  
**TURNING**

---

In the field of high precision machining, MG also offers CNC turning service. We have state-of-the-art CNC turning machines.

Thanks to the computerized detection of work phases, the company can guarantee constant real-time control of the progress of production, together with the immediate traceability of the processes carried out or still in progress.



# EXTRUDED TECHNOLOGY

*The aluminum extrusion process makes it possible to obtain profiles of infinite, even complex shapes.*

By varying the shape of the profile, changing the contact surface with the air and, consequently, the dissipation capacity.

By varying the shape of the profile, changing the contact surface with the air and, consequently, the dissipation capacity.

---

The extruded heat sinks are presented subdivided by shape (T, H, L, K, E, U, P), width and height, and organized in increasing order of size. MG follows mechanical processes following the customer's requests, guaranteeing reliability and quality of the finished product.

**CODE** DE15\_20

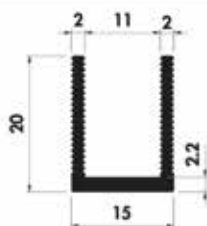

<b>Kg/mt</b>	0.25 Kg/mt
<b>L</b>	15 mm
<b>H</b>	20 mm
<b>Rth,F</b>	4.750 K/W
<b>Rth,N</b>	14.10 K/W
<b>Alloy</b>	6061

**CODE** DE20\_15

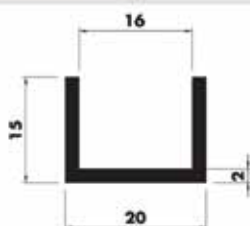

<b>Kg/mt</b>	0.24 Kg/mt
<b>L</b>	20 mm
<b>H</b>	5.590 K/W
<b>Rth,F</b>	16.60 K/W
<b>Rth,N</b>	15 mm
<b>Alloy</b>	6061

**CODE** DE21.3\_91.3

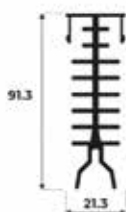

<b>Kg/mt</b>	1.898
<b>L</b>	21.3 mm
<b>H</b>	91.3 mm
<b>Alloy</b>	6061

**CODE** DE28\_32

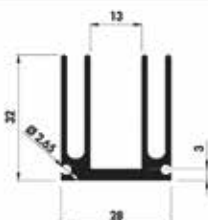

<b>Kg/mt</b>	0.73 Kg/mt
<b>L</b>	28 mm
<b>H</b>	32 mm
<b>Rth,F</b>	2.650 K/W
<b>Rth,N</b>	7.80 K/W
<b>Alloy</b>	6061

**CODE** DE29\_12

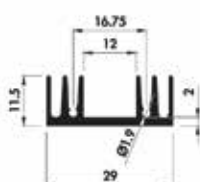

<b>Kg/mt</b>	0.35 Kg/mt
<b>L</b>	29 mm
<b>H</b>	11.50 mm
<b>Rth,F</b>	3.850 K/W
<b>Rth,N</b>	11.50 K/W
<b>Alloy</b>	6061

**CODE** DE30\_28

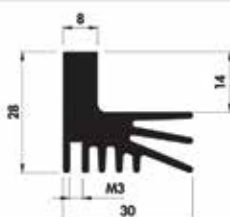

<b>Kg/mt</b>	0.98 Kg/mt
<b>L</b>	30 mm
<b>H</b>	28 mm
<b>Rth,F</b>	2.889 K/W
<b>Rth,N</b>	9.30 K/W
<b>Alloy</b>	6061

**CODE** DE30\_47

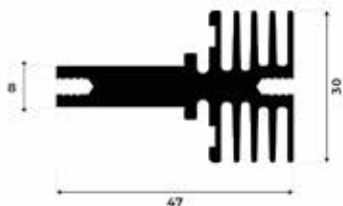

<b>Kg/mt</b>	1,3 Kg/mt
<b>L</b>	30 mm
<b>H</b>	47 mm
<b>Rth,F</b>	4.29 K/W
<b>Rth,N</b>	2.99 K/W
<b>Alloy</b>	6060

**CODE** DE31.5\_7.4



<b>Kg/mt</b>	5.068 Kg/mt
<b>L</b>	31.5 mm
<b>H</b>	7.4 mm
<b>Alloy</b>	6061

**CODE** DE31.7\_50

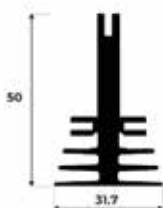

<b>Kg/mt</b>	1.161 Kg/mt
<b>L</b>	31.7 mm
<b>H</b>	50 mm
<b>Rth,F</b>	1.86 K/W
<b>Rth,N</b>	5.6 K/W
<b>Alloy</b>	6061

**CODE** DE34.5\_12

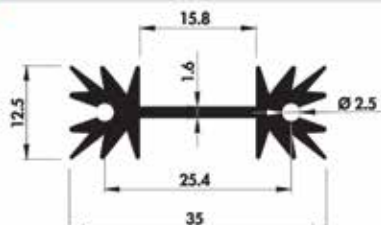

<b>Kg/mt</b>	0.43 Kg/mt
<b>L</b>	34.5 mm
<b>H</b>	12.50 mm
<b>Rth,F</b>	3.450 K/W
<b>Rth,N</b>	10.20 K/W
<b>Alloy</b>	6061

**CODE** DE34\_60

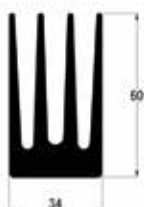

<b>Kg/mt</b>	2.84 Kg/mt
<b>L</b>	34 mm
<b>H</b>	60 mm
<b>Rth,F</b>	1.170 K/W
<b>Rth,N</b>	3.50 K/W
<b>Alloy</b>	6061

**CODE** DE35\_44

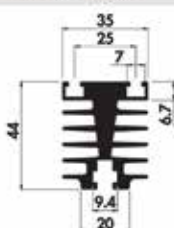

<b>Kg/mt</b>	2 Kg/mt
<b>L</b>	35 mm
<b>H</b>	44 mm
<b>Rth,F</b>	1.880 K/W
<b>Rth,N</b>	5.60 K/W
<b>Alloy</b>	6061

**CODE** DE38\_20

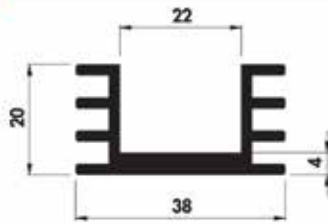

Kg/mt	0.71 Kg/mt
L	38 mm
H	20 mm
Rth,F	3.250 K/W
Rth,N	9.50 K/W
Alloy	6061

**CODE** DE40\_35

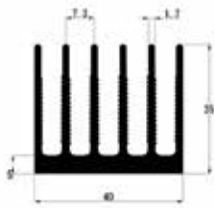

Kg/mt	1.73 Kg/mt
L	40 mm
H	35 mm
Rth,F	1.17 K/W
Rth,N	3.50 K/W
Alloy	6061

**CODE** DE40\_60

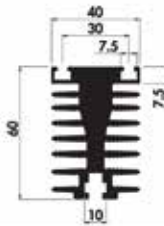

Kg/mt	3.41 Kg/mt
L	40 mm
H	1.450 K/W
Rth,F	4.30 K/W
Rth,N	60 mm
Alloy	6061

**CODE** DE44\_11

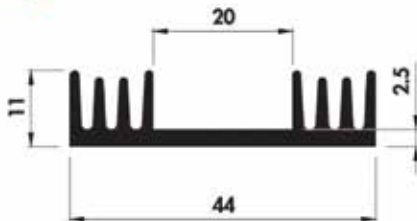

Kg/mt	0.56 Kg/mt
L	44 mm
H	11 mm
Rth,F	3.250 K/W
Rth,N	9.09 K/W
Alloy	6061

**CODE** DE45\_14

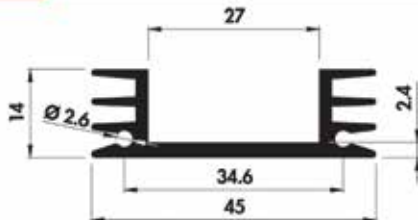

Kg/mt	0.55 Kg/mt
L	45 mm
H	14 mm
Rth,F	3.210 K/W
Rth,N	9.70 K/W
Alloy	6061

**CODE** DE46-33

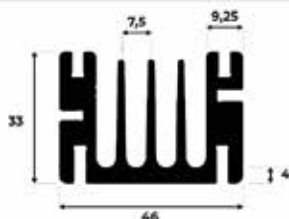

Kg/mt	2.077 Kg/mt
L	100 mm
Rth,F	0.87 K/W
Rth,N	2.58 K/W
H	33 mm



**CODE** DE46-33

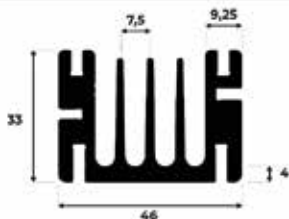

Kg/mt	2.077 Kg/mt
L	100 mm
Rth,F	0.87 K/W
Rth,N	2.58 K/W
H	33 mm

**CODE** DE48\_33

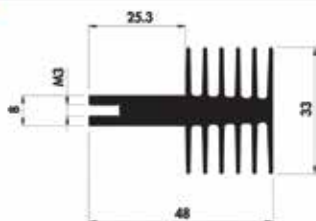

Kg/mt	1.45 Kg/mt
L	48 mm
H	33 mm
Rth,F	1.990 K/W
Rth,N	5.90 K/W
Alloy	6061

**CODE** DE48\_40

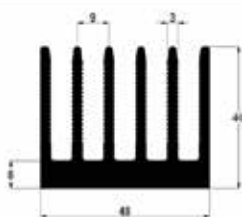

Kg/mt	2.45 Kg/mt
L	48 mm
H	40 mm
Rth,F	1.240 K/W
Rth,N	3.70 K/W
Alloy	6061

**CODE** DE50\_24

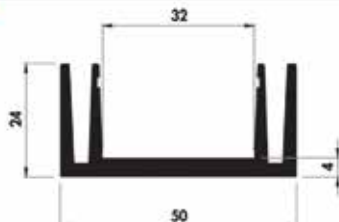

Kg/mt	1.03 Kg/mt
L	50 mm
H	2.750 K/W
Rth,F	8.30 K/W
Rth,N	24 mm
Alloy	6061

**CODE** DE50\_28

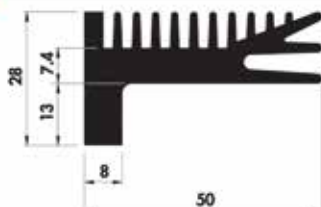

Kg/mt	1.65 Kg/mt
L	50 mm
H	28 mm
Rth,F	2.410 K/W
Rth,N	7.20 K/W
Alloy	6061

**CODE** DE52\_20

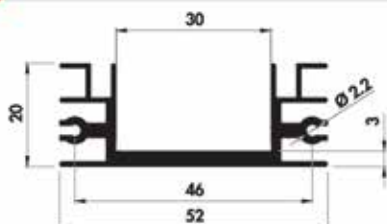

Kg/mt	0.73 Kg/mt
L	52 mm
H	0.259 K/W
Rth,F	6.75 K/W
Rth,N	20 mm
Alloy	6061

**CODE** DE52\_40

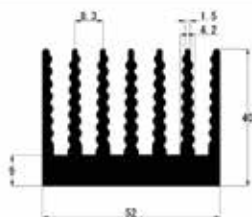

Kg/mt	2.79 Kg/mt
L	52 mm
H	40 mm
Rth,F	1.050 K/W
Rth,N	3.10 K/W
Alloy	6061

**CODE** DE54\_38

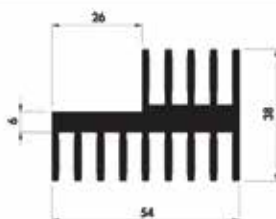

Kg/mt	2.20 Kg/mt
L	54 mm
H	38 mm
Rth,F	4.50 K/W
Rth,N	4.50 K/W
Alloy	6061

**CODE** DE60\_24

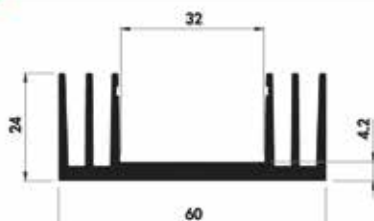

Kg/mt	1.22 Kg/mt
L	60 mm
H	2.210 K/W
Rth,F	6.03 K/W
Rth,N	24 mm
Alloy	6061

**CODE** DE65\_19.5

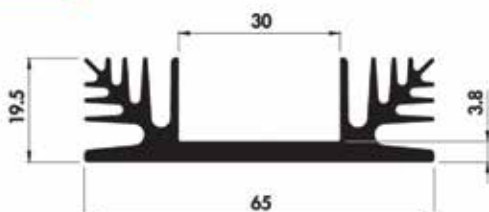

Kg/mt	1.25 Kg/mt
L	65 mm
H	1.989 K/W
Rth,F	5.85 K/W
Rth,N	19.50 mm
Alloy	6061

**CODE** DE66\_30

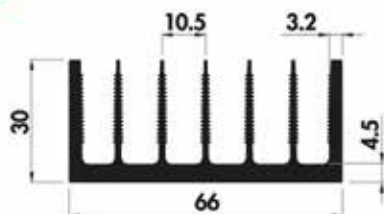

Kg/mt	1,742 Kg/mt
L	66 mm
Rth,F	0,99 K/W
Rth,N	2,9 K/W
H	30 mm

**CODE** DE66\_33

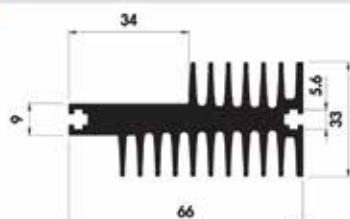

Kg/mt	2.43 Kg/mt
L	66 mm
H	33 mm
Rth,F	1.480 K/W
Rth,N	4.40 K/W
Alloy	6061

**CODE** DE66\_40

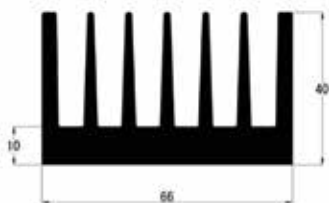

Kg/mt	3.47 Kg/mt
L	66 mm
H	40 mm
Rth,F	0.990 K/W
Rth,N	3.10 K/W
Alloy	6061

**CODE** DE68\_90

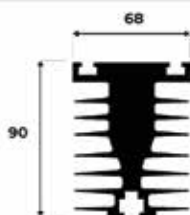

Kg/mt	8.66 Kg/mt
L	68 mm
Rth,F	0.411 K/W
Rth,N	1.22 K/W
H	90 mm

**CODE** DE70\_132



Kg/mt	13.22 Kg/mt
L	70 mm
H	132 mm
Rth,F	0.830 K/W
Rth,N	2.25 K/W
Alloy	6061

**CODE** DE80\_14

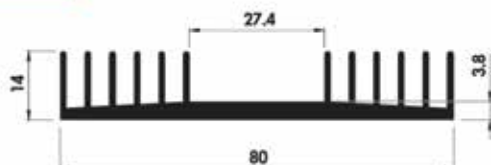

Kg/mt	1.18 Kg/mt
L	80 mm
H	14 mm
Rth,F	1.395 K/W
Rth,N	4.05 K/W
Alloy	6061

**CODE** DE80\_24

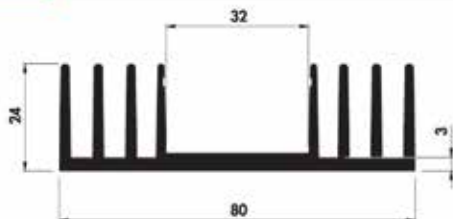

Kg/mt	1.72 Kg/mt
L	80 mm
H	24 mm
Rth,F	1.830 K/W
Rth,N	5.40 K/W
Alloy	6061

**CODE** DE82\_32

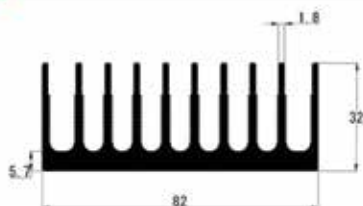

Kg/mt	2.99 Kg/mt
L	82 mm
H	32 mm
Rth,F	0.670 K/W
Rth,N	2.60 K/W
Alloy	6061

**CODE** DE84\_14

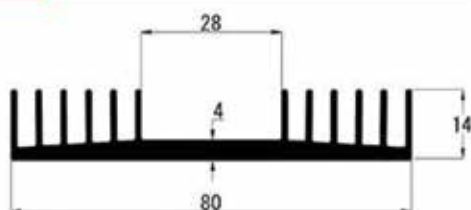

<b>Kg/mt</b>	1,95 Kg/mt
<b>L</b>	80 mm
<b>Rth,F</b>	3,45 K/W
<b>Rth,N</b>	10,2 K/W
<b>H</b>	14 mm
<b>Alloy</b>	6060

**CODE** DE88\_35

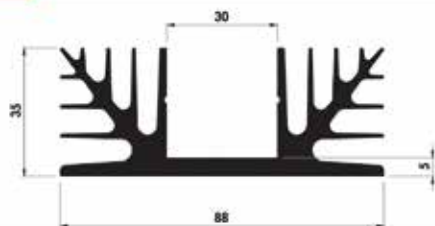

<b>Kg/mt</b>	2,80 Kg/mt
<b>L</b>	88 mm
<b>H</b>	35 mm
<b>Rth,F</b>	1,395 K/W
<b>Rth,N</b>	4,05 K/W
<b>Alloy</b>	6061

**CODE** DE90\_29.5

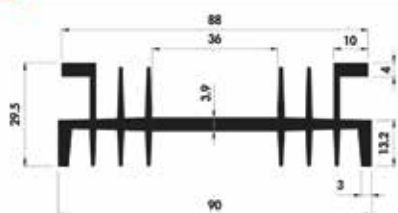

<b>Kg/mt</b>	1,86 Kg/mt
<b>L</b>	90 mm
<b>H</b>	29,50 mm
<b>Rth,F</b>	1,650 K/W
<b>Rth,N</b>	4,90 K/W
<b>Alloy</b>	6061

**CODE** DE94\_14\_A

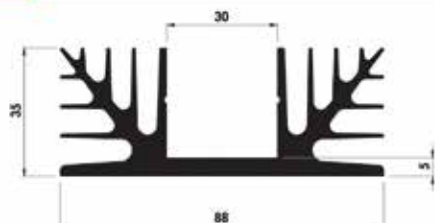

<b>Kg/mt</b>	1,64 Kg/mt
<b>L</b>	94 mm
<b>H</b>	14,50 mm
<b>Rth,F</b>	1,629 K/W
<b>Rth,N</b>	4,86 K/W
<b>Alloy</b>	6061

**CODE** DE95\_70

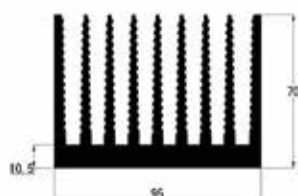

<b>Kg/mt</b>	7,25 Kg/mt
<b>L</b>	95 mm
<b>H</b>	70 mm
<b>Rth,F</b>	0,580 K/W
<b>Rth,N</b>	1,70 K/W
<b>Alloy</b>	6061

**CODE** DE96.5\_25

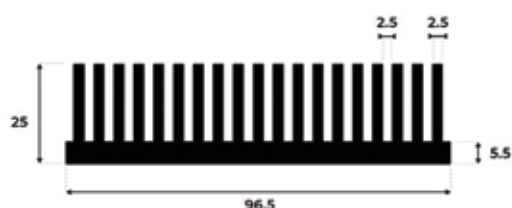

<b>Kg/mt</b>	3,934 Kg/mt
<b>L</b>	96,5 mm
<b>H</b>	25 mm
<b>Rth,F</b>	0,594 K/W
<b>Rth,N</b>	1,78 K/W

**CODE** DE97\_25.5

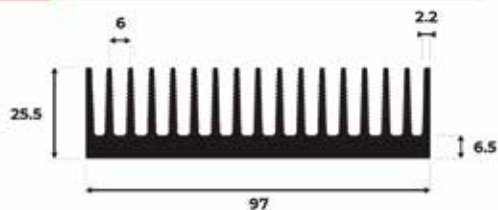

Kg/mt	3.40 Kg/mt
L	97 mm
H	25.5 mm
Rth,F	0.423 K/W
Rth,N	1.25 K/W
Alloy	6061

**CODE** DE100\_15

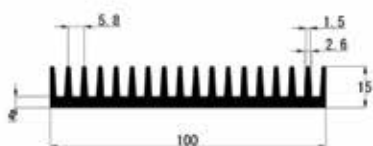

Kg/mt	2.16 Kg/mt
L	100 mm
H	15 mm
Rth,F	1.020 K/W
Rth,N	3.10 K/W
Alloy	6061

**CODE** DE100\_25

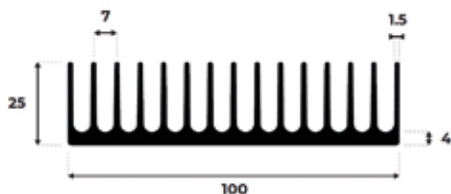

Kg/mt	2.66 Kg/mt
L	100 mm
H	25 mm
Rth,F	0.484 K/W
Rth,N	1.43 K/W
Alloy	6061

**CODE** DE100\_40

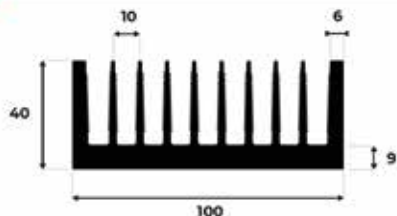

Kg/mt	5.12 Kg/mt
L	100 mm
H	40 mm
Rth,F	1.19 K/W
Rth,N	40 mm
Alloy	6061

**CODE** DE100\_50

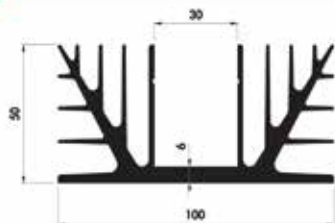

Kg/mt	4.90 Kg/mt
L	100 mm
H	50 mm
Rth,F	1.125 K/W
Rth,N	3.24 K/W
Alloy	6061

**CODE** DE100\_95.2

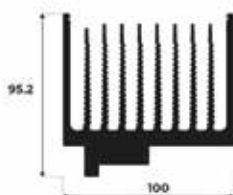

Kg/mt	8.548 Kg/mt
L	100 mm
H	95.2 mm
Rth,F	0.47 K/W
Rth,N	1.4 K/W
Alloy	6061

**CODE** DE100\_120

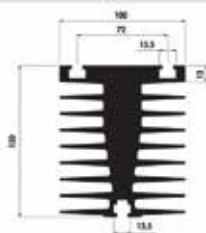

<b>Kg/mt</b>	15.64 Kg/mt
<b>L</b>	100 mm
<b>H</b>	120 mm
<b>Rth,F</b>	0.790 K/W
<b>Rth,N</b>	2.30 K/W
<b>Alloy</b>	6061

**CODE** DE105\_38

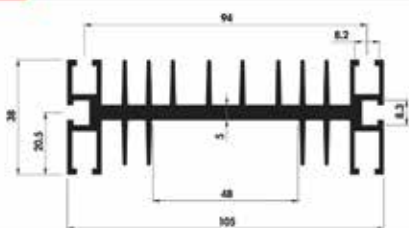

<b>Kg/mt</b>	2.83 Kg/mt
<b>L</b>	105 mm
<b>H</b>	38 mm
<b>Rth,F</b>	1.210 K/W
<b>Rth,N</b>	3.60 K/W
<b>Alloy</b>	6061

**CODE** DE112\_72

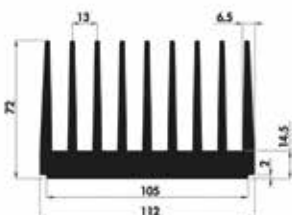

<b>Kg/mt</b>	9.81 Kg/mt
<b>L</b>	112 mm
<b>H</b>	72 mm
<b>Rth,F</b>	0.590 K/W
<b>Rth,N</b>	1.62 K/W
<b>Alloy</b>	6061

**CODE** DE113\_37

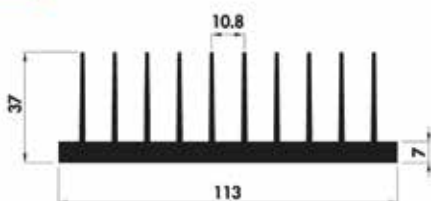

<b>Kg/mt</b>	3.43 Kg/mt
<b>L</b>	113 mm
<b>H</b>	37 mm
<b>Rth,F</b>	0.790 K/W
<b>Rth,N</b>	2.30 K/W
<b>Alloy</b>	6061

**CODE** DE115\_33

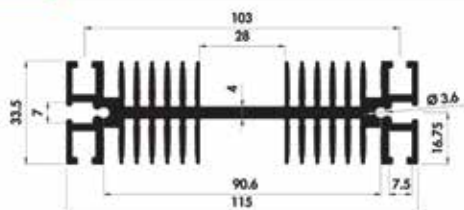

<b>Kg/mt</b>	3.83 Kg/mt
<b>L</b>	115 mm
<b>H</b>	33.50 mm
<b>Rth,F</b>	0.880 K/W
<b>Rth,N</b>	2.43 K/W
<b>Alloy</b>	6061

**CODE** DE115\_80

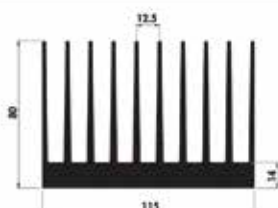

<b>Kg/mt</b>	9.52 Kg/mt
<b>L</b>	115 mm
<b>H</b>	80 mm
<b>Rth,F</b>	0.510 K/W
<b>Rth,N</b>	1.50 K/W
<b>Alloy</b>	6061

**CODE** DE120\_40

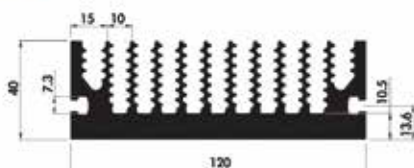

<b>Kg/mt</b>	6.70 Kg/mt
<b>L</b>	120 mm
<b>H</b>	40 mm
<b>Rth,F</b>	0.620 K/W
<b>Rth,N</b>	1.71 K/W
<b>Alloy</b>	6061

**CODE** DE120\_40\_A

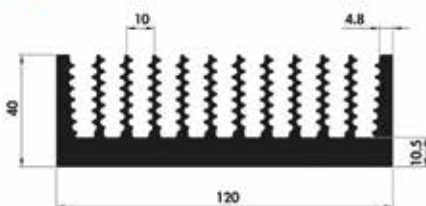

<b>Kg/mt</b>	6.51 Kg/mt
<b>L</b>	120 mm
<b>H</b>	40 mm
<b>Rth,F</b>	0.610 K/W
<b>Rth,N</b>	1.71 K/W
<b>Alloy</b>	6061

**CODE** DE120\_60

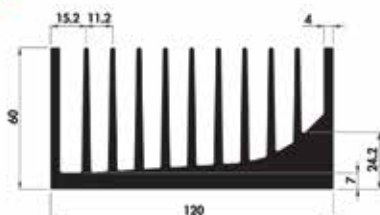

<b>Kg/mt</b>	8.37 Kg/mt
<b>L</b>	120 mm
<b>H</b>	60 mm
<b>Rth,F</b>	0.580 K/W
<b>Rth,N</b>	1.70 K/W
<b>Alloy</b>	6061

**CODE** DE120\_60\_B

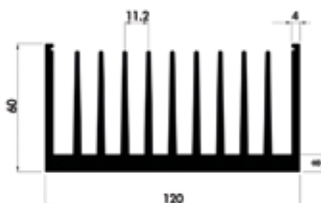

<b>Kg/mt</b>	7.29 Kg/mt
<b>L</b>	120 mm
<b>H</b>	60 mm
<b>Rth,F</b>	0.560 K/W
<b>Rth,N</b>	1.70 K/W
<b>Alloy</b>	6061

**CODE** DE120\_63

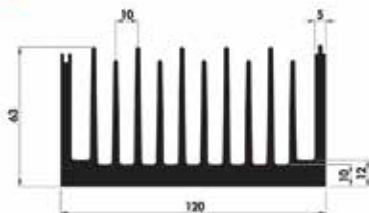

<b>Kg/mt</b>	8.39 Kg/mt
<b>L</b>	120 mm
<b>H</b>	63 mm
<b>Rth,F</b>	0.540 K/W
<b>Rth,N</b>	60 K/W
<b>Alloy</b>	6061

**CODE** DE120\_64

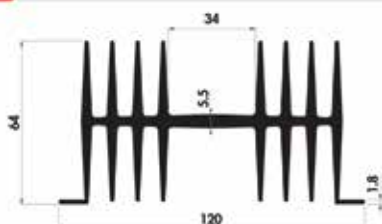

<b>Kg/mt</b>	4.97 Kg/mt
<b>L</b>	120 mm
<b>H</b>	64 mm
<b>Rth,F</b>	1.010 K/W
<b>Rth,N</b>	2.79 K/W
<b>Alloy</b>	6061

**CODE** DE120\_70

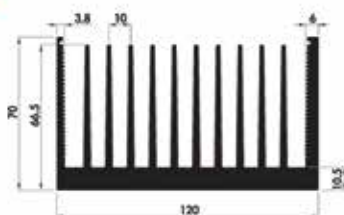

<b>Kg/mt</b>	8.96 Kg/mt
<b>L</b>	120 mm
<b>H</b>	70 mm
<b>Rth,F</b>	0.410 K/W
<b>Rth,N</b>	1.20 K/W
<b>Alloy</b>	6061

**CODE** DE120\_120

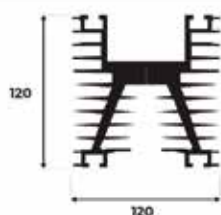

<b>Kg/mt</b>	11.19 Kg/mt
<b>L</b>	120 mm
<b>H</b>	120 mm
<b>Rth,F</b>	0.251 K/W
<b>Rth,N</b>	0.74 K/W
<b>Alloy</b>	6061

**CODE** DE121\_58.5

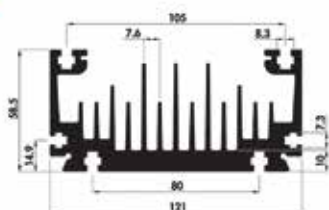

<b>Kg/mt</b>	7.13 Kg/mt
<b>L</b>	121 mm
<b>H</b>	58.50 mm
<b>Rth,F</b>	0.580 K/W
<b>Rth,N</b>	1.70 K/W
<b>Alloy</b>	6061

**CODE** DE125\_76

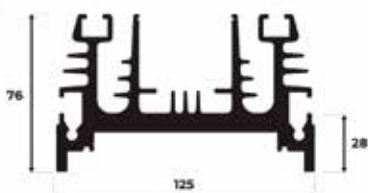

<b>Kg/mt</b>	7.081 Kg/mt
<b>L</b>	125 mm
<b>H</b>	76 mm
<b>Rth,F</b>	0.275 K/W
<b>Rth,N</b>	0.84 K/W
<b>Alloy</b>	6061

**CODE** DE125\_125

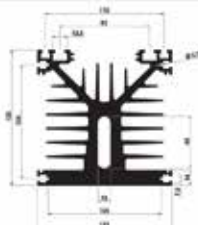

<b>Kg/mt</b>	15.53 Kg/mt
<b>L</b>	125 mm
<b>H</b>	125 mm
<b>Rth,F</b>	0.390 K/W
<b>Rth,N</b>	1.08 K/W
<b>Alloy</b>	6061

**CODE** DE125\_135\_A

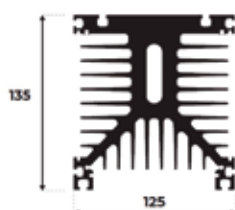

<b>Kg/mt</b>	17.61 Kg/mt
<b>L</b>	125 mm
<b>H</b>	135 mm
<b>Rth,F</b>	0.168 K/W
<b>Rth,N</b>	0.50 K/W
<b>Alloy</b>	6061



**CODE** DE125\_135\_B

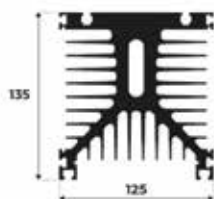

Kg/mt	17.9 Kg/mt
L	125 mm
H	135 mm
Rth,F	0.38 K/W
Rth,N	1.10 K/W
Alloy	6061

**CODE** DE126\_63.5

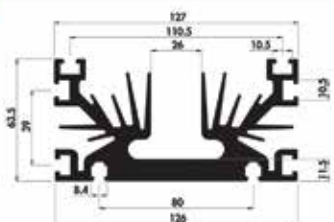

Kg/mt	8.21 Kg/mt
L	126 mm
H	63.5 mm
Rth,F	0.549 K/W
Rth,N	1.62 K/W
Alloy	6061

**CODE** DE128\_57

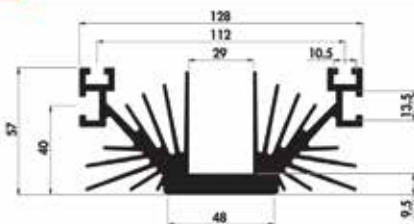

Kg/mt	5.95 Kg/mt
L	128 mm
H	57 mm
Rth,F	0.522 K/W
Rth,N	1.53 K/W
Alloy	6061

**CODE** DE130\_52

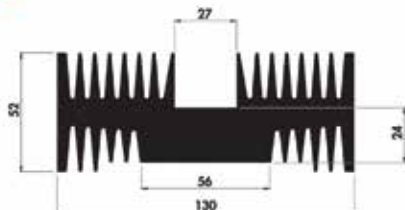

Kg/mt	11.18 Kg/mt
L	130 mm
H	52 mm
Rth,F	1.75 K/W
Rth,N	52 mm
Alloy	6061

**CODE** DE130\_84

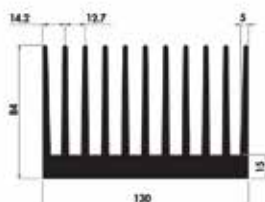

Kg/mt	13.44 Kg/mt
L	130 mm
H	84 mm
Rth,F	0.470 K/W
Rth,N	1.26 K/W
Alloy	6061

**CODE** DE130\_130

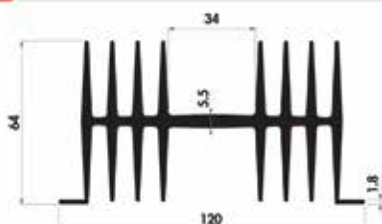

Kg/mt	12.26 Kg/mt
L	130 mm
H	130 mm
Rth,F	0.680 K/W
Rth,N	1.89 K/W
Alloy	6061

**CODE** DE135\_25

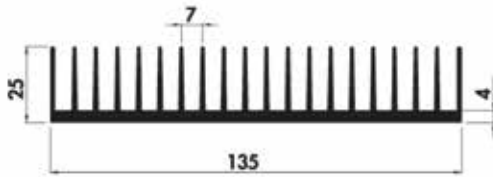

<b>Kg/mt</b>	3.25 Kg/mt
<b>L</b>	135 mm
<b>H</b>	25 mm
<b>Rth,F</b>	0.650 K/W
<b>Rth,N</b>	1.90 K/W
<b>Alloy</b>	6061

**CODE** DE135\_135.5

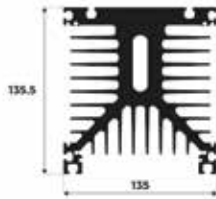

<b>Kg/mt</b>	21.9 Kg/mt
<b>L</b>	135 mm
<b>H</b>	135.5 mm
<b>Rth,F</b>	0.18 K/W
<b>Rth,N</b>	0.81 K/W
<b>Alloy</b>	6061

**CODE** DE138\_40

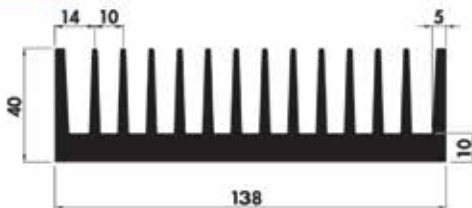

<b>Kg/mt</b>	7.29 Kg/mt
<b>L</b>	138 mm
<b>H</b>	40 mm
<b>Rth,F</b>	0.650 K/W
<b>Rth,N</b>	1.90 K/W
<b>Alloy</b>	6061

**CODE** DE138\_50.5

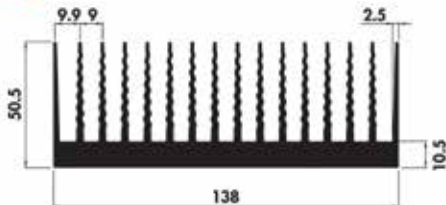

<b>Kg/mt</b>	7.55 Kg/mt
<b>L</b>	138 mm
<b>H</b>	50.5 mm
<b>Rth,F</b>	0.51 K/W
<b>Rth,N</b>	1.50 K/W
<b>Alloy</b>	6061

**CODE** DE138\_62

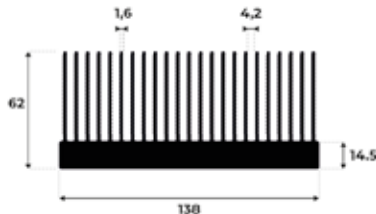

<b>Kg/mt</b>	10.15 Kg/mt
<b>L</b>	138 mm
<b>H</b>	62 mm
<b>Rth,F</b>	2.75 K/W
<b>Rth,N</b>	1.69 K/W
<b>Alloy</b>	6060

**CODE** DE140\_26

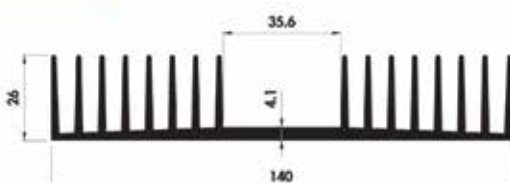

<b>Kg/mt</b>	4.90 Kg/mt
<b>L</b>	100 mm
<b>H</b>	50 mm
<b>Rth,F</b>	1.125 K/W
<b>Rth,N</b>	3.24 K/W
<b>Alloy</b>	6061

**CODE** DE140\_90

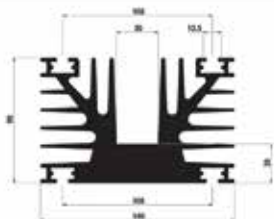

Kg/mt	15.23 Kg/mt
L	140 mm
H	90 mm
Rth,F	0.459 K/W
Rth,N	1.35 K/W
Alloy	6061

**CODE** DE142\_120

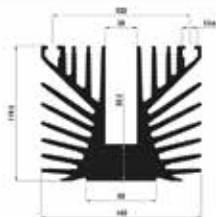

Kg/mt	19.50 Kg/mt
L	142 mm
H	119.5 mm
Rth,F	0.380 K/W
Rth,N	1.08 K/W
Alloy	6061

**CODE** DE149.5\_9.2



Kg/mt	2.306 Kg/mt
L	149.5 mm
H	9.2 mm
Rth,F	0.58 K/W
Rth,N	1.7 K/W
Alloy	6061

**CODE** DE150\_27\_AF

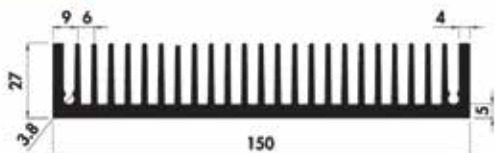

Kg/mt	5.29 Kg/mt
L	150 mm
H	27 mm
Rth,F	0.513 K/W
Rth,N	1.53 K/W
Alloy	6061

**CODE** DE150\_27

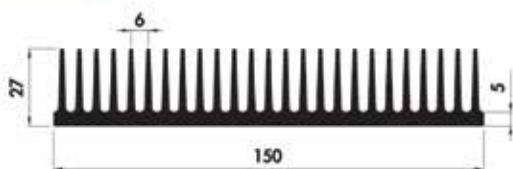

Kg/mt	5.17 Kg/mt
L	150 mm
H	27 mm
Rth,F	0.522 K/W
Rth,N	1.53 K/W
Alloy	6061

**CODE** DE150\_27\_A

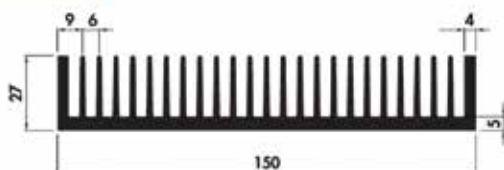

Kg/mt	5.27 Kg/mt
L	150 mm
H	27 mm
Rth,F	0.513 K/W
Rth,N	1.53 K/W
Alloy	6061

**CODE** DE150\_40

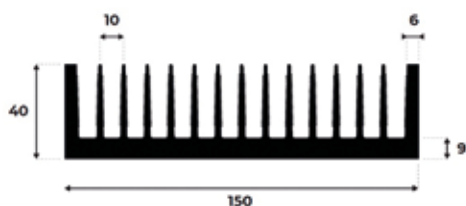

<b>Kg/mt</b>	7.42 Kg/mt
<b>L</b>	150 mm
<b>H</b>	40 mm
<b>Rth,F</b>	0.299 K/W
<b>Rth,N</b>	0.68 K/W
<b>Alloy</b>	6061

**CODE** DE150\_50

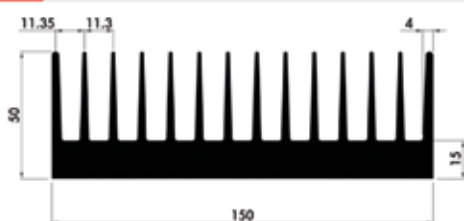

<b>Kg/mt</b>	9.58 Kg/mt
<b>L</b>	150 mm
<b>H</b>	50 mm
<b>Rth,F</b>	0.580 K/W
<b>Rth,N</b>	1.70 K/W
<b>Alloy</b>	6061

**CODE** DE150\_62



<b>Kg/mt</b>	12.33 Kg/mt
<b>L</b>	150 mm
<b>H</b>	62 mm
<b>Rth,F</b>	0.252 K/W
<b>Rth,N</b>	0.73 K/W
<b>Alloy</b>	6061

**CODE** DE150\_72

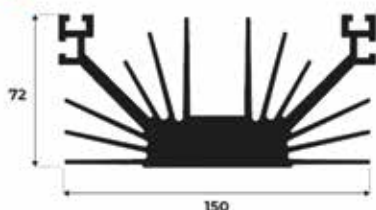

<b>Kg/mt</b>	8.934 Kg/mt
<b>L</b>	150 mm
<b>H</b>	72 mm
<b>Rth,F</b>	0.69 K/W
<b>Rth,N</b>	1.89 K/W
<b>Alloy</b>	6061

**CODE** DE150\_83

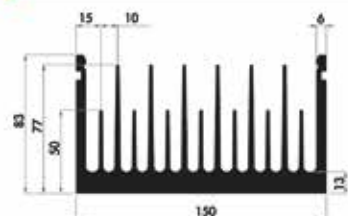

<b>Kg/mt</b>	12.33 Kg/mt
<b>L</b>	150 mm
<b>H</b>	83 mm
<b>Rth,F</b>	0.460 K/W
<b>Rth,N</b>	1.26 K/W
<b>Alloy</b>	6061

**CODE** DE115\_35

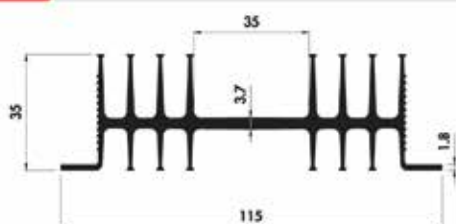

<b>Kg/mt</b>	2.15 Kg/mt
<b>L</b>	115 mm
<b>H</b>	35 mm
<b>Rth,F</b>	1.350 K/W
<b>Rth,N</b>	3.69 K/W
<b>Alloy</b>	6061

**CODE** DE160\_40

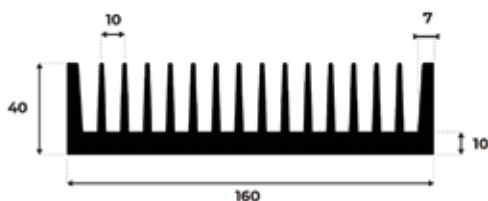

Kg/mt	8.64 Kg/mt
L	160 mm
H	40 mm
Rth,F	0.281 K/W
Rth,N	0.64 K/W
Alloy	6061

**CODE** DE160\_50

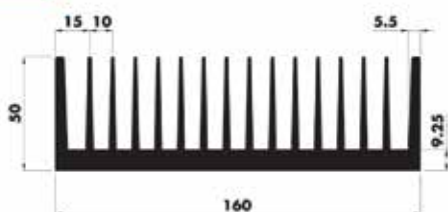

Kg/mt	8.86 Kg/mt
L	160 mm
H	50 mm
Rth,F	0.459 K/W
Rth,N	1.35 K/W
Alloy	6061

**CODE** DE162\_25

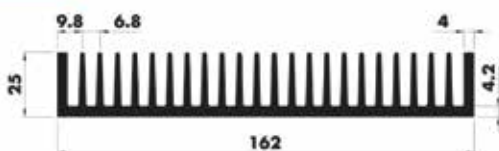

Kg/mt	5.23 Kg/mt
L	162 mm
H	25 mm
Rth,F	0.531 K/W
Rth,N	1.62 K/W
Alloy	6061

**CODE** DE164\_93.5

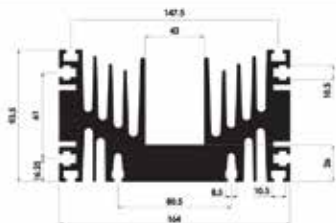

Kg/mt	19 Kg/mt
L	164 mm
H	93.5 mm
Rth,F	0.405 K/W
Rth,N	1.17 K/W
Alloy	6061

**CODE** DE173\_28

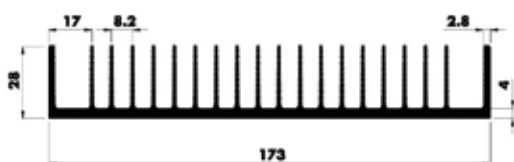

Kg/mt	4.22 Kg/mt
L	173 mm
H	28 mm
Rth,F	0.369 K/W
Rth,N	1.08 K/W
Alloy	6061

**CODE** DE178\_80

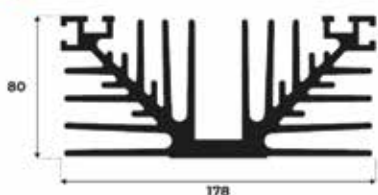

Kg/mt	12.782 Kg/mt
L	178 mm
H	80 mm
Rth,F	0.370 K/W
Rth,N	1.08 K/W
Alloy	6061

**CODE** DE180\_80

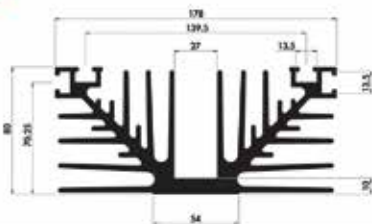

<b>Kg/mt</b>	12.78 Kg/mt
<b>L</b>	180 mm
<b>H</b>	80 mm
<b>Rth,F</b>	0.378 K/W
<b>Rth,N</b>	1.17 K/W
<b>Alloy</b>	6061

**CODE** DE188\_30

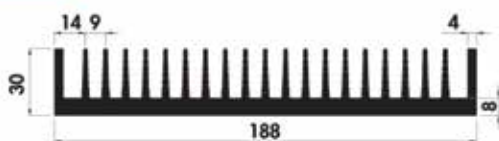

<b>Kg/mt</b>	7.36 Kg/mt
<b>L</b>	188 mm
<b>H</b>	30 mm
<b>Rth,F</b>	0.531 K/W
<b>Rth,N</b>	1.62 K/W
<b>Alloy</b>	6061

**CODE** DE190.5\_83

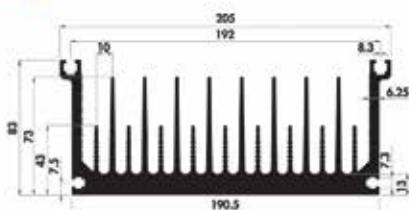

<b>Kg/mt</b>	14.83 Kg/mt
<b>L</b>	190.5 mm
<b>H</b>	83 mm
<b>Rth,F</b>	0.369 K/W
<b>Rth,N</b>	.08 K/W
<b>Alloy</b>	6061

**CODE** DE190.5\_83\_A

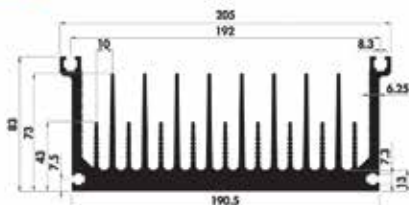

<b>Kg/mt</b>	14.75 Kg/mt
<b>L</b>	190.5 mm
<b>H</b>	83 mm
<b>Rth,F</b>	0.410 K/W
<b>Rth,N</b>	1.20 K/W
<b>Alloy</b>	6061

**CODE** DE190\_50.1

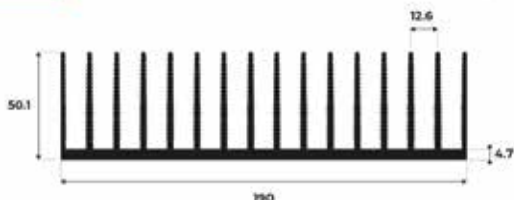

<b>Kg/mt</b>	6.799 Kg/mt
<b>L</b>	190 mm
<b>H</b>	50.1 mm
<b>Rth,F</b>	0.45 K/W
<b>Rth,N</b>	1.26 K/W
<b>Alloy</b>	6061

**CODE** DE197\_20

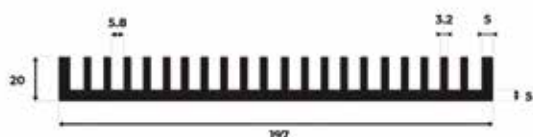

<b>Kg/mt</b>	5.64 Kg/mt
<b>L</b>	197 mm
<b>H</b>	20 mm
<b>Rth,F</b>	0.242 K/W
<b>Rth,N</b>	0.72 K/W
<b>Alloy</b>	6061

**CODE** DE200\_84

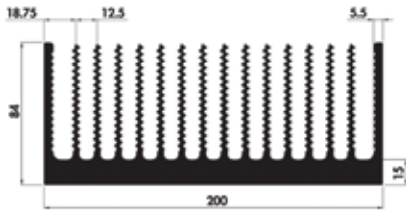

<b>Kg/mt</b>	17.74 Kg/mt
<b>L</b>	200 mm
<b>H</b>	84 mm
<b>Rth,F</b>	0.279 K/W
<b>Rth,N</b>	0.90 K/W
<b>Alloy</b>	6061

**CODE** DE200\_15

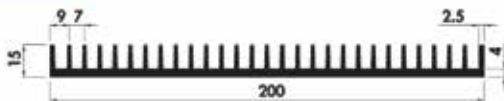

<b>Kg/mt</b>	3.90 Kg/mt
<b>L</b>	200 mm
<b>H</b>	15 mm
<b>Rth,F</b>	0.621 K/W
<b>Rth,N</b>	1.89 K/W
<b>Alloy</b>	6061

**CODE** DE200\_25



<b>Kg/mt</b>	5.38 Kg/mt
<b>L</b>	200 mm
<b>H</b>	25 mm
<b>Rth,F</b>	0.477 K/W
<b>Rth,N</b>	1.50 K/W
<b>Alloy</b>	6061

**CODE** DE200\_40

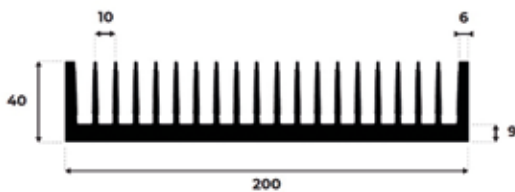

<b>Kg/mt</b>	9.72 Kg/mt
<b>L</b>	200 mm
<b>H</b>	40 mm
<b>Rth,F</b>	0.154 K/W
<b>Rth,N</b>	0.46 K/W
<b>Alloy</b>	6061

**CODE** DE200\_60

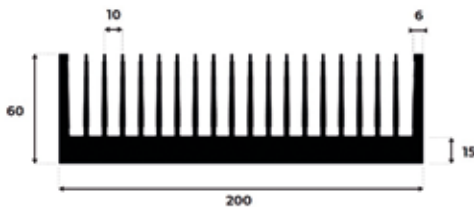

<b>Kg/mt</b>	15.16 Kg/mt
<b>L</b>	200 mm
<b>H</b>	60 mm
<b>Rth,F</b>	0.121 K/W
<b>Rth,N</b>	0.36 K/W
<b>Alloy</b>	6061

**CODE** DE200\_72

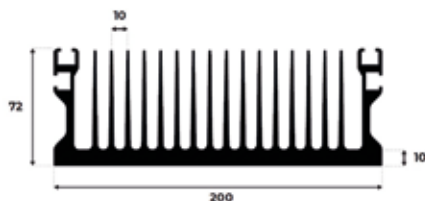

<b>Kg/mt</b>	14.53 Kg/mt
<b>L</b>	200 mm
<b>H</b>	72 mm
<b>Rth,F</b>	0.130 K/W
<b>Rth,N</b>	0.38 K/W
<b>Alloy</b>	6061

**CODE** DE200\_83

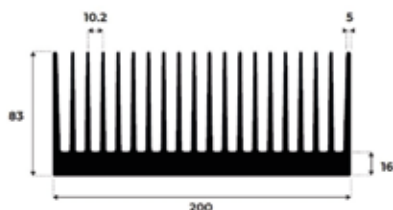

<b>Kg/mt</b>	19.9 Kg/mt
<b>L</b>	200 mm
<b>H</b>	83 mm
<b>Rth,F</b>	0.119 K/W
<b>Rth,N</b>	0.35 K/W
<b>Alloy</b>	6061

**CODE** DE200\_84

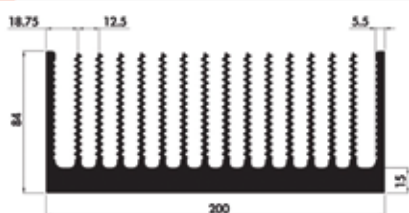

<b>Kg/mt</b>	17.74 Kg/mt
<b>L</b>	200 mm
<b>H</b>	84 mm
<b>Rth,F</b>	0.279 K/W
<b>Rth,N</b>	0.90 K/W
<b>Alloy</b>	6061

**CODE** DE200\_86

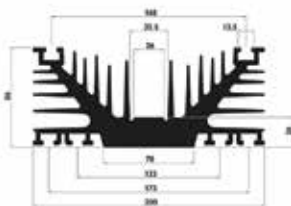

<b>Kg/mt</b>	19.17 Kg/mt
<b>L</b>	200 mm
<b>H</b>	86 mm
<b>Rth,F</b>	1.17 K/W
<b>Rth,N</b>	1.20 K/W
<b>Alloy</b>	6061

**CODE** DE210\_70



<b>Kg/mt</b>	19.99 Kg/mt
<b>L</b>	210 mm
<b>H</b>	68 mm
<b>Rth,F</b>	0.369 K/W
<b>Rth,N</b>	1.08 K/W
<b>Alloy</b>	6061

**CODE** DE215\_77

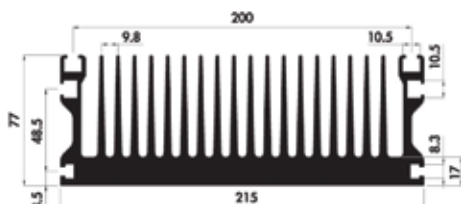

<b>Kg/mt</b>	22.15 Kg/mt
<b>L</b>	215 mm
<b>H</b>	77 mm
<b>Rth,F</b>	0.330 K/W
<b>Rth,N</b>	0.88 K/W
<b>Alloy</b>	6061

**CODE** DE215\_77

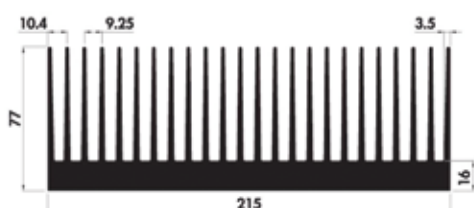

<b>Kg/mt</b>	19.80 Kg/mt
<b>L</b>	215 mm
<b>H</b>	77 mm
<b>Rth,F</b>	0.279 K/W
<b>Rth,N</b>	0.81 K/W
<b>Alloy</b>	6061



**CODE** DE216\_77



<b>Kg/mt</b>	24 Kg/mt
<b>L</b>	216 mm
<b>H</b>	77 mm
<b>Rth,F</b>	0.297 K/W
<b>Rth,N</b>	0.88 K/W
<b>Alloy</b>	6061

**CODE** DE216\_83

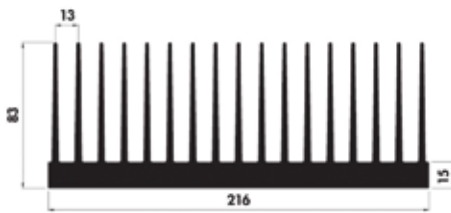

<b>Kg/mt</b>	18.06 Kg/mt
<b>L</b>	216 mm
<b>H</b>	83 mm
<b>Rth,F</b>	0.324 K/W
<b>Rth,N</b>	0.99 K/W
<b>Alloy</b>	6061

**CODE** DE220\_46.5

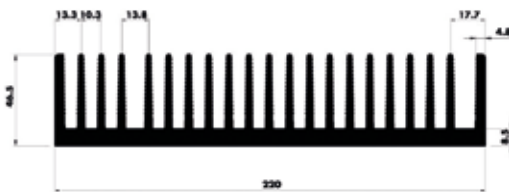

<b>Kg/mt</b>	11.27 Kg/mt
<b>L</b>	220 mm
<b>H</b>	46.5 mm
<b>Rth,F</b>	0.378 K/W
<b>Rth,N</b>	1.17 K/W
<b>Alloy</b>	6061

**CODE** DE220\_60

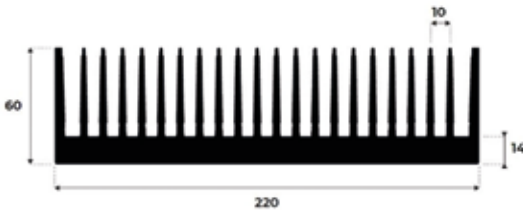

<b>Kg/mt</b>	16.719 Kg/mt
<b>L</b>	220 mm
<b>H</b>	60 mm
<b>Rth,F</b>	0.36 K/W
<b>Rth,N</b>	0.39 K/W
<b>Alloy</b>	6061

**CODE** DE220\_77

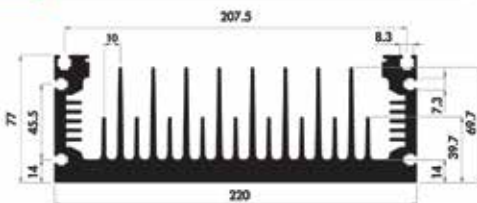

<b>Kg/mt</b>	17.54 Kg/mt
<b>L</b>	220 mm
<b>H</b>	77 mm
<b>Rth,F</b>	0.351 K/W
<b>Rth,N</b>	1.08 K/W
<b>Alloy</b>	6061

**CODE** DE226\_80

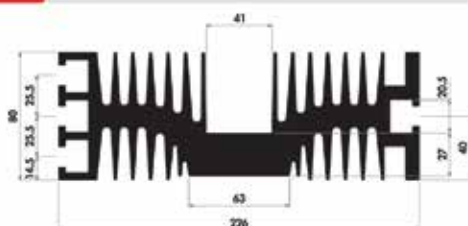

<b>Kg/mt</b>	23.74 Kg/mt
<b>L</b>	226 mm
<b>H</b>	80 mm
<b>Rth,F</b>	0.369 K/W
<b>Rth,N</b>	1.08 K/W
<b>Alloy</b>	6061

**CODE** DE228\_32.2

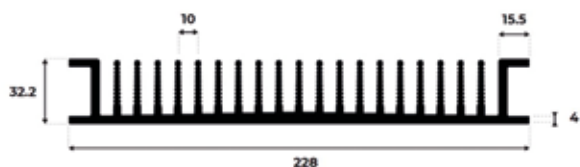

<b>Kg/mt</b>	8.132 Kg/mt
<b>L</b>	228 mm
<b>H</b>	32.2 mm
<b>Rth,F</b>	0.150 K/W
<b>Rth,N</b>	0.43 K/W
<b>Alloy</b>	6061

**CODE** DE235\_60

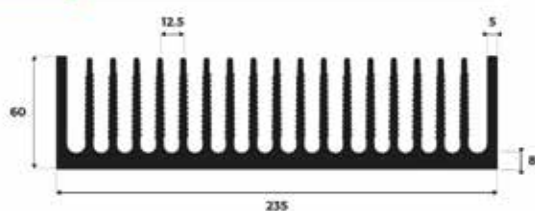

<b>Kg/mt</b>	14.893 Kg/mt
<b>L</b>	235 mm
<b>H</b>	60 mm
<b>Rth,F</b>	0.310 K/W
<b>Rth,N</b>	0.9 K/W
<b>Alloy</b>	6061

**CODE** DE240\_16

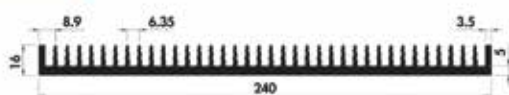

<b>Kg/mt</b>	5.57 Kg/mt
<b>L</b>	240 mm
<b>H</b>	16 mm
<b>Rth,F</b>	0.531 K/W
<b>Rth,N</b>	1.62 K/W
<b>Alloy</b>	6061

**CODE** DE240\_108\_A

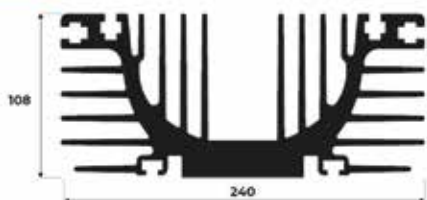

<b>Kg/mt</b>	25.056 Kg/mt
<b>L</b>	240mm
<b>H</b>	108 mm
<b>Rth,F</b>	0.324 K/W
<b>Rth,N</b>	0.99 K/W
<b>Alloy</b>	6061

**CODE** DE240\_108\_B

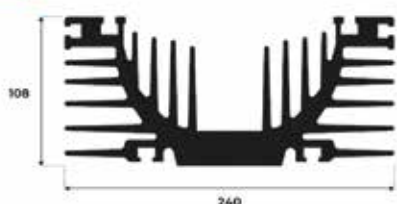

<b>Kg/mt</b>	26.101 Kg/mt
<b>L</b>	240mm
<b>H</b>	108 mm
<b>Rth,F</b>	0.324 K/W
<b>Rth,N</b>	0.99 K/W
<b>Alloy</b>	6061

**CODE** DE240\_112



<b>Kg/mt</b>	29.824 Kg/mt
<b>L</b>	240mm
<b>H</b>	112 mm
<b>Rth,F</b>	0.345 K/W
<b>Rth,N</b>	1.05 K/W
<b>Alloy</b>	6061

**CODE** DE245.6



Kg/mt	6.39 Kg/mt
L	245.6 mm
H	0.423 K/W
Rth,F	1.26 K/W
Rth,N	25 mm
Alloy	6061

**CODE** DE249\_75.6

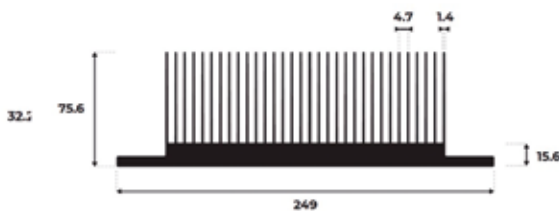

Kg/mt	15.841 Kg/mt
L	249 mm
H	75.6 mm
Rth,F	0.082 K/W
Rth,N	0.28 K/W
Alloy	6061

**CODE** DE250\_40.5

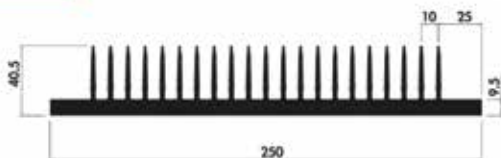

Kg/mt	10.97 Kg/mt
L	250 mm
H	40.50 mm
Rth,F	0.390 K/W
Rth,N	1.08 K/W
Alloy	6061

**CODE** DE250\_40

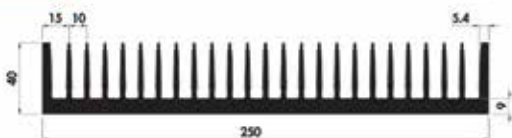

Kg/mt	11.94 Kg/mt
L	250 mm
H	40 mm
Rth,F	0.333 K/W
Rth,N	0.99 K/W
Alloy	6061

**CODE** DE250\_40\_A

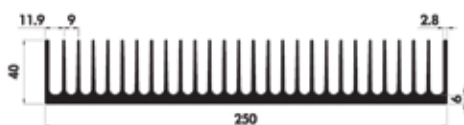

Kg/mt	9.66 Kg/mt
L	250 mm
H	40 mm
Rth,F	0.390 K/W
Rth,N	1.08 K/W
Alloy	6061

**CODE** DE250\_40\_D

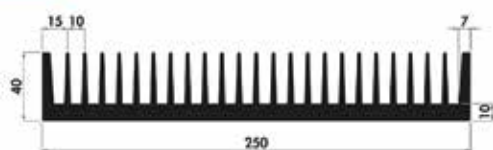

Kg/mt	13.22 Kg/mt
L	250 mm
H	40 mm
Rth,F	0.430 K/W
Rth,N	1.30 K/W
Alloy	6061

**CODE** DE250\_83

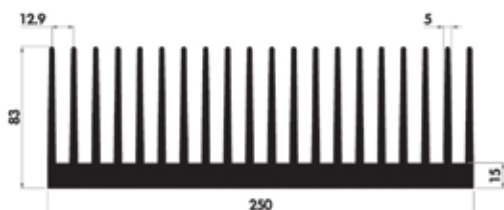

<b>Kg/mt</b>	24.68 Kg/mt
<b>L</b>	250 mm
<b>H</b>	83 mm
<b>Rth,F</b>	0.310 K/W
<b>Rth,N</b>	0.90 K/W
<b>Alloy</b>	6061

**CODE** DE260\_67.5

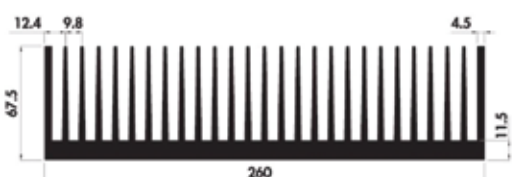

<b>Kg/mt</b>	20.68 Kg/mt
<b>L</b>	260 mm
<b>H</b>	67.50 mm
<b>Rth,F</b>	0.290 K/W
<b>Rth,N</b>	0.81 K/W
<b>Alloy</b>	6061

**CODE** DE260\_67.5\_A



<b>Kg/mt</b>	18.18 Kg/mt
<b>L</b>	260 mm
<b>H</b>	67.50 mm
<b>Rth,F</b>	0.279 K/W
<b>Rth,N</b>	0.90 K/W
<b>Alloy</b>	6061

**CODE** DE265\_74

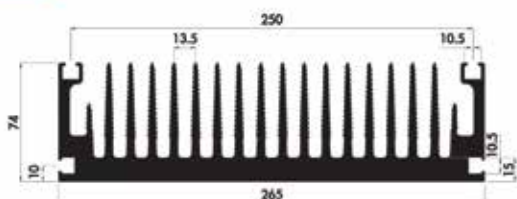

<b>Kg/mt</b>	24.92 Kg/mt
<b>L</b>	265 mm
<b>H</b>	74 mm
<b>Rth,F</b>	0.297 K/W
<b>Rth,N</b>	0.88 K/W
<b>Alloy</b>	6061

**CODE** DE265\_74\_A



<b>Kg/mt</b>	24.13 Kg/mt
<b>L</b>	265 mm
<b>H</b>	74 mm
<b>Rth,F</b>	0.330 K/W
<b>Rth,N</b>	0.88 K/W
<b>Alloy</b>	6061

**CODE** DE270\_73

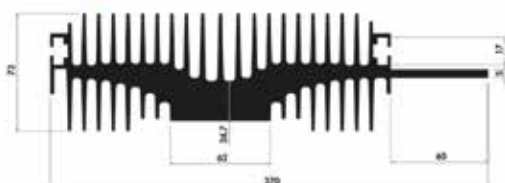

<b>Kg/mt</b>	18.74 Kg/mt
<b>L</b>	270 mm
<b>H</b>	73 mm
<b>Rth,F</b>	0.350 K/W
<b>Rth,N</b>	0.99 K/W
<b>Alloy</b>	6061

**CODE** DE290\_85

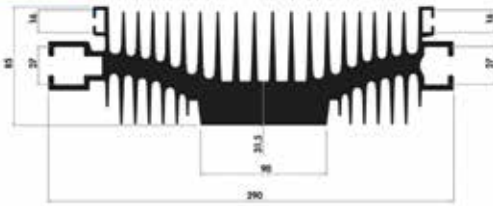

Kg/mt	25.40 Kg/mt
L	290 mm
H	0.279 K/W
Rth,F	0.81 K/W
Rth,N	85 mm
Alloy	6061

**CODE** DE300\_25\_A

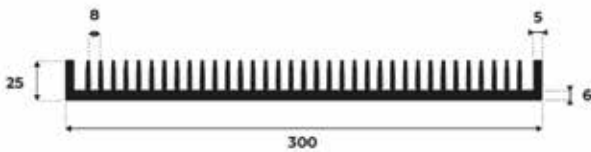

Kg/mt	9.022 Kg/mt
L	300 mm
H	25 mm
Rth,F	0.398 K/W
Rth,N	1.28 K/W
Alloy	6061

**CODE** DE300\_25\_B

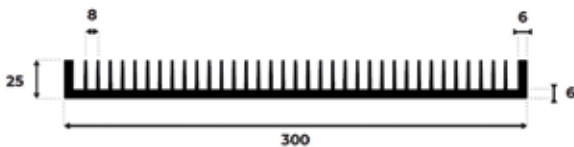

Kg/mt	9.01 Kg/mt
L	300 mm
H	25 mm
Rth,F	0.121 K/W
Rth,N	0.36 K/W
Alloy	6061

**CODE** DE300\_27

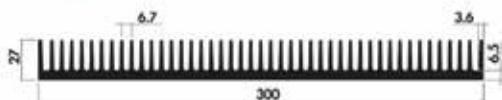

Kg/mt	11.90 Kg/mt
L	300 mm
H	27 mm
Rth,F	0.390 K/W
Rth,N	1.08 K/W
Alloy	6061

**CODE** DE300\_36

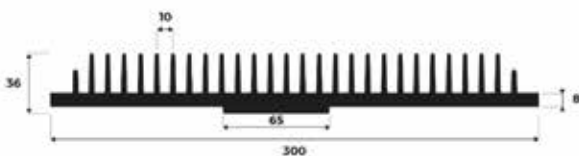

Kg/mt	11.285 Kg/mt
L	300 mm
H	36 mm
Rth,F	0.279 K/W
Rth,N	0.81 K/W
Alloy	6061

**CODE** DE300\_40

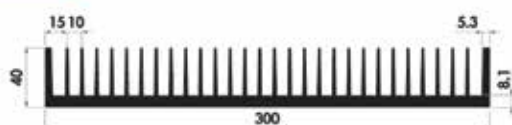

Kg/mt	13.02 Kg/mt
L	300 mm
H	40 mm
Rth,F	0.342 K/W
Rth,N	1.10 K/W
Alloy	6061

**CODE** DE300\_40\_A

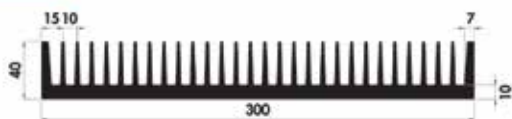

Kg/mt	15.80 Kg/mt
L	300 mm
H	40 mm
Rth,F	0.351 K/W
Rth,N	1.08 K/W
Alloy	6061

**CODE** DE300\_40\_B



Kg/mt	14.35 Kg/mt
L	300 mm
H	40 mm
Rth,F	0.288 K/W
Rth,N	0.88 K/W
Alloy	6061

**CODE** DE300\_60

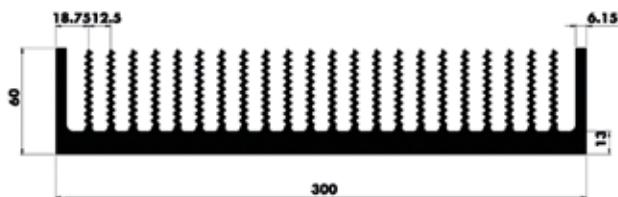

Kg/mt	20.53 Kg/mt
L	300 mm
H	60 mm
Rth,F	0.279 K/W
Rth,N	0.81 K/W
Alloy	6061

**CODE** DE300\_70.4

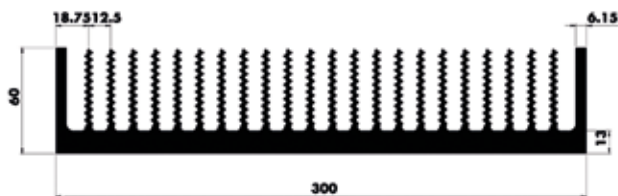

Kg/mt	18.77 Kg/mt
L	300 mm
H	70.4 mm
Rth,F	0.279 K/W
Rth,N	0.90 K/W
Alloy	6061

**CODE** DE300\_83\_A

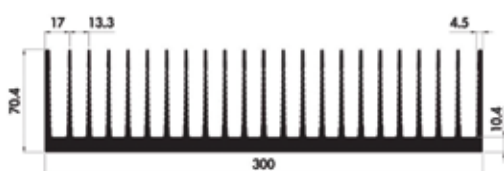

Kg/mt	23.07 Kg/mt
L	300 mm
H	83 mm
Rth,F	0.261 K/W
Rth,N	0.81 K/W
Alloy	6061

**CODE** DE300\_84\_C

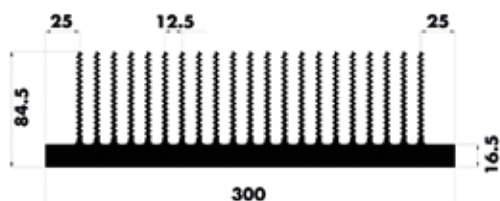

Kg/mt	24.99 Kg/mt
L	300 mm
H	84.50 mm
Rth,F	0.250 K/W
Rth,N	0.72 K/W
Alloy	6061

**CODE** DE300\_84

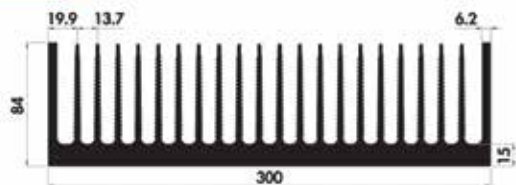

Kg/mt	28.44 Kg/mt
L	300 mm
H	84 mm
Rth,F	0.280 K/W
Rth,N	0.81 K/W
Alloy	6061

**CODE** DE300\_84\_A

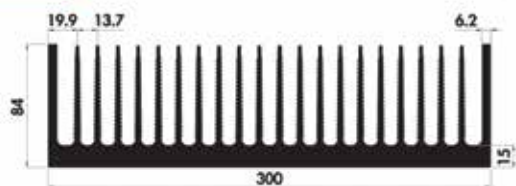

Kg/mt	26.64 Kg/mt
L	300 mm
H	84 mm
Rth,F	0.230 K/W
Rth,N	0.63 K/W
Alloy	6061

**CODE** DE300\_84\_C

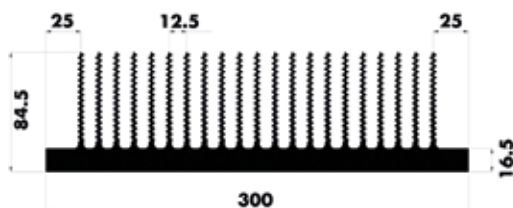

Kg/mt	24.99 Kg/mt
L	300 mm
H	84.50 mm
Rth,F	0.250 K/W
Rth,N	0.72 K/W
Alloy	6061

**CODE** DE315\_72.7\_A

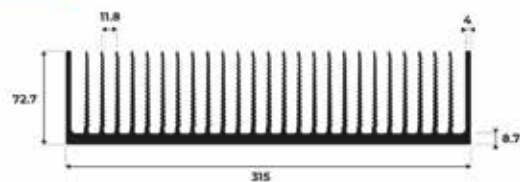

Kg/mt	19.217 Kg/mt
L	315 mm
H	72.7 mm
Rth,F	0.23 K/W
Rth,N	0.63 K/W
Alloy	6061

**CODE** DE315\_72.7\_B

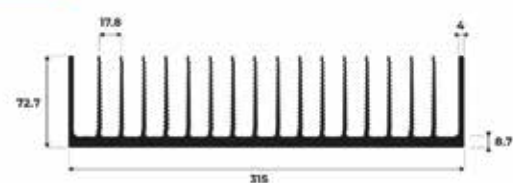

Kg/mt	15.466 Kg/mt
L	315 mm
H	72.7 mm
Rth,F	0.348 K/W
Rth,N	1.10 K/W
Alloy	6061

**CODE** DE345\_61.5

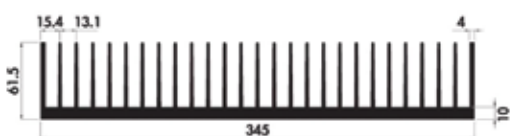

Kg/mt	20.07 Kg/mt
L	345 mm
H	61.5 mm
Rth,F	0.290 K/W
Rth,N	0.81 K/W
Alloy	6061

**CODE** DE362\_35

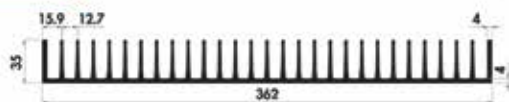

<b>Kg/mt</b>	11.13 Kg/mt
<b>L</b>	362 mm
<b>H</b>	35 mm
<b>Rth,F</b>	0.342 K/W
<b>Rth,N</b>	0.99 K/W
<b>Alloy</b>	6061

**CODE** DE380\_60\_E

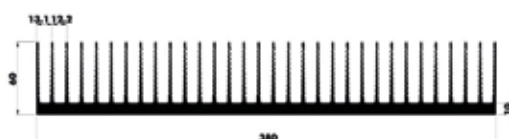

<b>Kg/mt</b>	18.35 Kg/mt
<b>L</b>	380 mm
<b>H</b>	60 mm
<b>Rth,F</b>	0.243 K/W
<b>Rth,N</b>	0.72 K/W
<b>Alloy</b>	6061

**CODE** DE400\_40

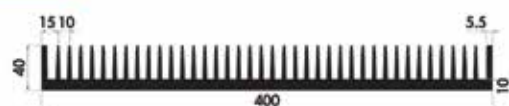

<b>Kg/mt</b>	21.44 Kg/mt
<b>L</b>	400 mm
<b>H</b>	40 mm
<b>Rth,F</b>	0.279 K/W
<b>Rth,N</b>	0.81 K/W
<b>Alloy</b>	6061

**CODE** DE400\_61

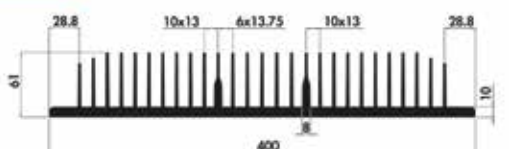

<b>Kg/mt</b>	22.35 Kg/mt
<b>L</b>	400 mm
<b>H</b>	0.290 K/W
<b>Rth,F</b>	0.81 K/W
<b>Rth,N</b>	61 mm
<b>Alloy</b>	6061

**CODE** DE470\_83



<b>Kg/mt</b>	25.60 Kg/mt
<b>L</b>	470 mm
<b>H</b>	83 mm
<b>Rth,F</b>	0.087 K/W
<b>Rth,N</b>	0.23 K/W
<b>Alloy</b>	6061





# WELDED TECHNOLOGY

*To obtain profiles of large dimensions, which cannot be made directly with extrusion, two or more extruded profiles can be welded together.*

Welding is extremely flexible to the customer's dimensional needs and can be used for any modification to existing profiles. MG Italy makes its experience and availability available to its customers in order to create the required product.

---

We provide special extruded profiles already chamfered for a simpler and more efficient MIG and TIG welding operation. This technique allows us to create profiles with a maximum width of 900 mm.

**CODE DSAXX\_YY**

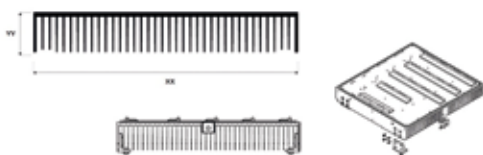

L	XX mm
H	YY mm
Alloy	6060

**CODE DSBXX\_YY**

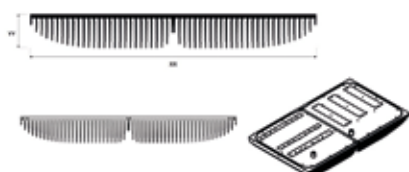

L	XX mm
H	YY mm
Alloy	6060

**CODE DE207\_187.3**

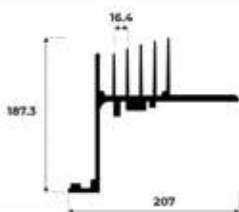

Kg/mt	6 Kg/mt
L	207 mm
H	187.3 mm
Rth,F	0.127 K/W
Rth,N	0.39 K/W
Alloy	6061

**CODE DE320\_75.5**

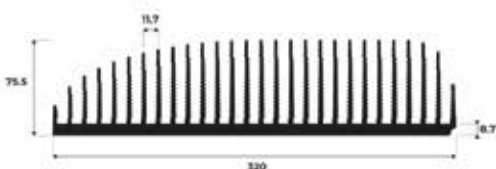

Kg/mt	18.128 Kg/mt
L	320 mm
H	75.5 mm
Rth,F	0.27 K/W
Rth,N	0.80 K/W
Alloy	6061

**CODE DS340\_70.4**

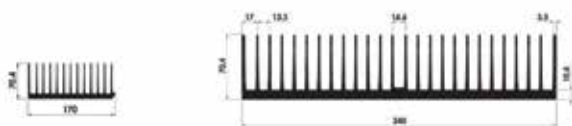

Kg/mt	21.29 Kg/mt
L	340 mm
H	70.40 mm
Rth,F	0.261 K/W
Rth,N	0.81 K/W
Alloy	6061

**CODE DS360\_83.5**

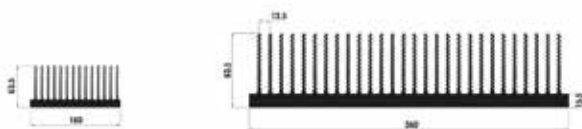

Kg/mt	30.40 Kg/mt
L	360 mm
H	0.117 K/W
Rth,F	0.36 K/W
Rth,N	83.50 mm
Alloy	6061

**CODE DS398\_70.9**



Kg/mt	28.70 Kg/mt
L	398 mm
H	70.90 mm
Rth,F	0.63 K/W
Rth,N	0.60 K/W
Alloy	6061

**CODE DS400\_60**



Kg/mt	30.60 Kg/mt
L	400 mm
H	60 mm
Rth,F	0.117 K/W
Rth,N	0.36 K/W
Alloy	6061

**CODE DS400\_83**



Kg/mt	39.75 Kg/mt
L	400 mm
H	83 mm
Rth,F	0.63 K/W
Rth,N	0.60 K/W
Alloy	6061

**CODE DS400\_85**

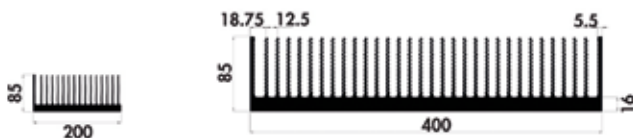

Kg/mt	35.76 Kg/mt
L	400 mm
H	85 mm
Rth,F	0.190 K/W
Rth,N	0.54 K/W
Alloy	6061

**CODE DS430\_77\_A**



Kg/mt	39.60 Kg/mt
L	430 mm
H	77 mm
Rth,F	0.190 K/W
Rth,N	0.54 K/W
Alloy	6061

**CODE DS432\_77**



Kg/mt	48 Kg/mt
L	432 mm
H	77 mm
Rth,F	0.189 K/W
Rth,N	0.60 K/W
Alloy	6061

**CODE** DS432\_83



<b>Kg/mt</b>	36.13 Kg/mt
<b>L</b>	432 mm
<b>H</b>	83 mm
<b>Rth,F</b>	0.198 K/W
<b>Rth,N</b>	0.63 K/W
<b>Alloy</b>	6061

**CODE** DS440\_60



<b>Kg/mt</b>	34.54 Kg/mt
<b>L</b>	440 mm
<b>H</b>	60 mm
<b>Rth,F</b>	0.216 K/W
<b>Rth,N</b>	0.70 K/W
<b>Alloy</b>	6061

**CODE** DS450\_85

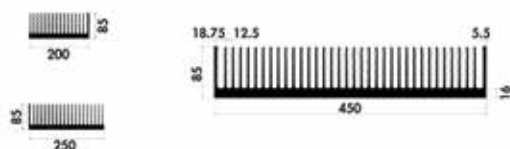

<b>Kg/mt</b>	40.13 Kg/mt
<b>L</b>	450 mm
<b>H</b>	85 mm
<b>Rth,F</b>	0.162 K/W
<b>Rth,N</b>	0.48 K/W
<b>Alloy</b>	6061

**CODE** DS460\_80.5



<b>Kg/mt</b>	34.95 Kg/mt
<b>L</b>	460 mm
<b>H</b>	80.50 mm
<b>Rth,F</b>	0.108 K/W
<b>Rth,N</b>	0.32 K/W
<b>Alloy</b>	6061

**CODE** DS500\_40



<b>Kg/mt</b>	23.87 Kg/mt
<b>L</b>	500 mm
<b>H</b>	40 mm
<b>Rth,F</b>	0.171 K/W
<b>Rth,N</b>	0.63 K/W
<b>Alloy</b>	6061

**CODE** DS500\_83



<b>Kg/mt</b>	49.36 Kg/mt
<b>L</b>	500 mm
<b>H</b>	83 mm
<b>Rth,F</b>	0.189 K/W
<b>Rth,N</b>	0.54 K/W
<b>Alloy</b>	6061

**CODE DS500\_85**



Kg/mt	44.51 Kg/mt
L	500 mm
H	85 mm
Rth,F	0.153 K/W
Rth,N	0.45 K/W
Alloy	6061

**CODE DS520\_67.5**



Kg/mt	41.36 Kg/mt
L	520 mm
H	67.50 mm
Rth,F	0.171 K/W
Rth,N	0.54 K/W
Alloy	6061

**CODE DS520\_67.5\_A**



Kg/mt	36.37 Kg/mt
L	520 mm
H	67.50 mm
Rth,F	0.190 K/W
Rth,N	0.54 K/W
Alloy	6061

**CODE DS550\_85**

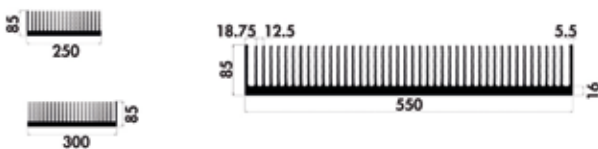

Kg/mt	48.88 Kg/mt
L	550 mm
H	85 mm
Rth,F	0.150 K/W
Rth,N	0.45 K/W
Alloy	6061

**CODE DS600\_25**



Kg/mt	18.02 Kg/mt
L	600 mm
H	25 mm
Rth,F	0.252 K/W
Rth,N	0.80 K/W
Alloy	6061

**CODE DS600\_40\_A**



Kg/mt	31.60 Kg/mt
L	600 mm
H	40 mm
Rth,F	0.72 K/W
Rth,N	0.70 K/W
Alloy	6061

**CODE** DS600\_70.4



<b>Kg/mt</b>	37.53 Kg/mt
<b>L</b>	600 mm
<b>H</b>	70.40 mm
<b>Rth,F</b>	0.190 K/W
<b>Rth,N</b>	0.54 K/W
<b>Alloy</b>	6061

**CODE** DS600\_83\_A

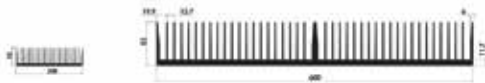

<b>Kg/mt</b>	46.15 Kg/mt
<b>L</b>	600 mm
<b>H</b>	83 mm
<b>Rth,F</b>	0.162 K/W
<b>Rth,N</b>	0.48 K/W
<b>Alloy</b>	6061

**CODE** DS600\_85



<b>Kg/mt</b>	53.25 Kg/mt
<b>L</b>	600 mm
<b>H</b>	85 mm
<b>Rth,F</b>	0.135 K/W
<b>Rth,N</b>	0.40 K/W
<b>Alloy</b>	6061

**CODE** DS690\_61.5

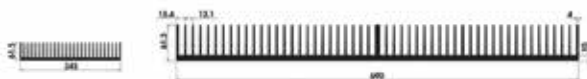

<b>Kg/mt</b>	40.15 Kg/mt
<b>L</b>	690 mm
<b>H</b>	61.50 mm
<b>Rth,F</b>	0.171 K/W
<b>Rth,N</b>	0.54 K/W
<b>Alloy</b>	6061

**CODE** DS700\_85

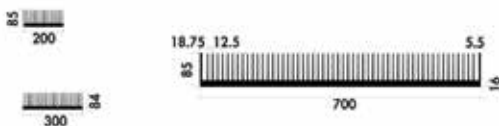

<b>Kg/mt</b>	62 Kg/mt
<b>L</b>	700 mm
<b>H</b>	85 mm
<b>Rth,F</b>	0.13 K/W
<b>Rth,N</b>	0.36 K/W
<b>Alloy</b>	6061

**CODE** DS750\_85

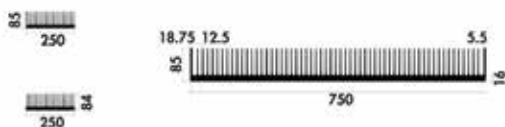

<b>Kg/mt</b>	66.37 Kg/mt
<b>L</b>	750 mm
<b>H</b>	85 mm
<b>Rth,F</b>	0.117 K/W
<b>Rth,N</b>	0.36 K/W
<b>Alloy</b>	6061

**CODE** DS800\_40



Kg/mt	42.87 Kg/mt
L	800 mm
H	40 mm
Rth,F	0.171 K/W
Rth,N	0.54 K/W
Alloy	6061

**CODE** DS800\_85

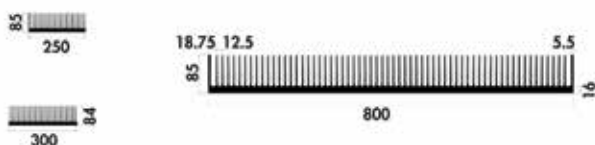

Kg/mt	70.75 Kg/mt
L	800 mm
H	85 mm
Rth,F	0.108 K/W
Rth,N	0.32 K/W
Alloy	6061

**CODE** DS850\_85

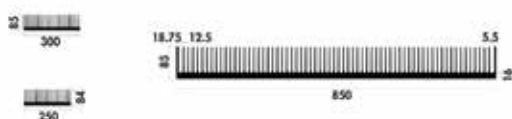

Kg/mt	75.12 Kg/mt
L	850 mm
H	85 mm
Rth,F	0.108 K/W
Rth,N	0.32 K/W
Alloy	6061

**CODE** DS900\_85



Kg/mt	79.49 Kg/mt
L	900 mm
H	85 mm
Rth,F	0.099 K/W
Rth,N	0.32 K/W
Alloy	6061

EXTRUDED  
TECHNOLOGY

WELDING  
TECHNOLOGY

ASSEMBLED  
TECHNOLOGY

HEATPLUS  
TECHNOLOGY

COLDPLATE  
TECHNOLOGY

PV  
PROFILES

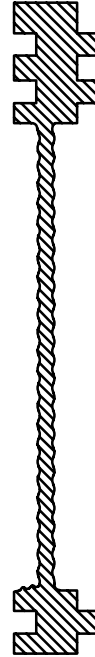
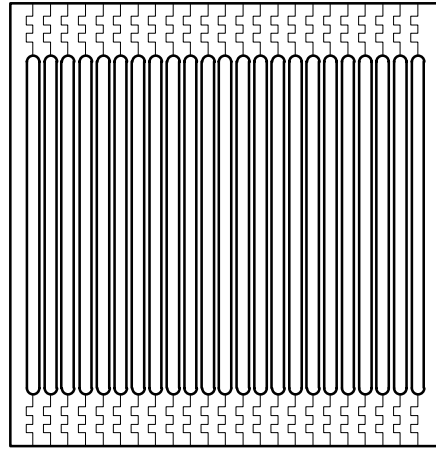

# ASSEMBLED TECHNOLOGY

*This line of products was born from the continuous and growing need to supply heat sinks with ever greater thermal performance.*

We worked on the section of the single fin, on the number of fins and on their arrangement. Obtained by mechanically assembling the single fins, the high efficiency heat sinks also offer high dimensional flexibility and the same mechanical characteristics as the extruded heat sinks, making them particularly

---

suitable for use in high power systems in forced convection.

Defined Assembled Profiles (PA) are divided by width and height of the single fin profile or module and organized in increasing order of size.



**CODE** DAAXX\_YY

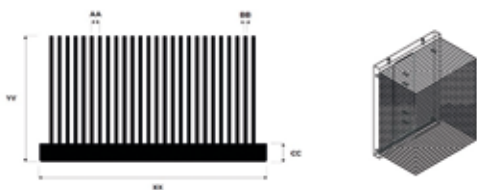

L	XX mm
H	YY mm
Alloy	1050

**CODE** DABXX\_YY

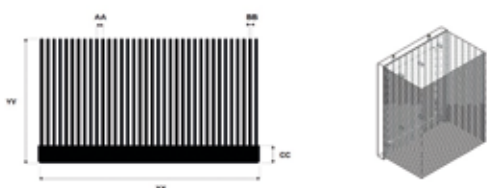

L	XX mm
H	YY mm
Alloy	1050

**CODE** DACXX\_YY

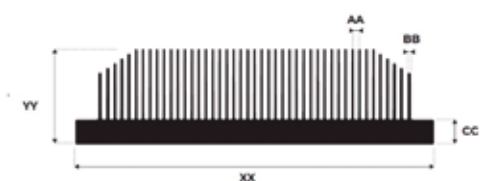

L	XX mm
H	YY mm
Alloy	1050

**CODE** DADXX\_YY

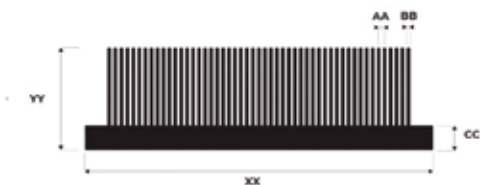

L	XX mm
H	YY mm
Alloy	1050

**CODE** DAEXX\_YY

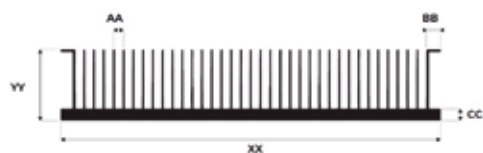

L	XX mm
H	YY mm
Alloy	1050

**CODE** DAFXX\_YY

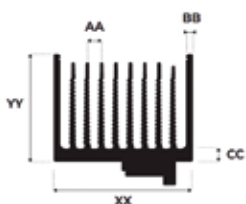

L	XX mm
H	YY mm
Alloy	1050

**CODE AE3.5\_41.5**

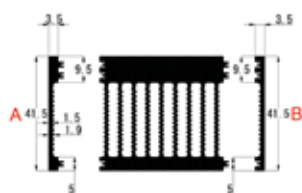

<b>Kg/mt</b>	0.28 Kg/mt
<b>L</b>	3.50 mm
<b>H</b>	41.50 mm
<b>Alloy</b>	6061

**CODE AE4.5\_65**



<b>Kg/mt</b>	0.77 Kg/mt
<b>L</b>	4.50 mm
<b>H</b>	65 mm
<b>Alloy</b>	6061

**CODE AE4.5\_70**



<b>Kg/mt</b>	0.39 Kg/mt
<b>L</b>	4.50 mm
<b>H</b>	70 mm
<b>Alloy</b>	6061

**CODE AE4.5\_76**

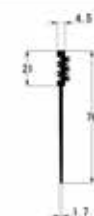

<b>Kg/mt</b>	0.47 Kg/mt
<b>L</b>	4.50 mm
<b>H</b>	76 mm
<b>Alloy</b>	6061

**CODE AE5.5\_90**

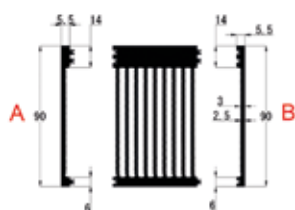

<b>Kg/mt</b>	0.81 Kg/mt
<b>L</b>	5.50 mm
<b>H</b>	90 mm
<b>Alloy</b>	6061

**CODE AE5.5\_125**

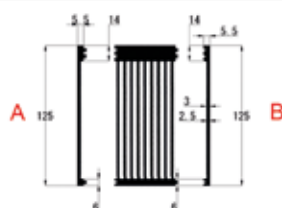

<b>Kg/mt</b>	1.06 Kg/mt
<b>L</b>	5.50 mm
<b>H</b>	125 mm
<b>Alloy</b>	6061

**CODE AE5.5\_54**



<b>Kg/mt</b>	0.61 Kg/mt
<b>L</b>	5.50 mm
<b>H</b>	54 mm
<b>Alloy</b>	6061

**CODE AE5.5\_61.2**

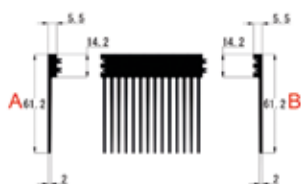

<b>Kg/mt</b>	0.44 Kg/mt
<b>L</b>	5.50 mm
<b>H</b>	61.20 mm
<b>Alloy</b>	6061

**CODE AE5.5\_75**

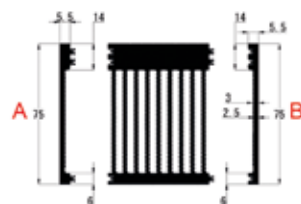

<b>Kg/mt</b>	0.45 Kg/mt
<b>L</b>	5.50 mm
<b>H</b>	75 mm
<b>Alloy</b>	6061

**CODE AE5.5\_105**

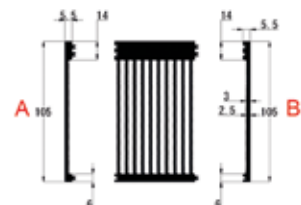

<b>Kg/mt</b>	0.83 Kg/mt
<b>L</b>	5.50 mm
<b>H</b>	105 mm
<b>Alloy</b>	6061

**CODE AE5.5\_90**

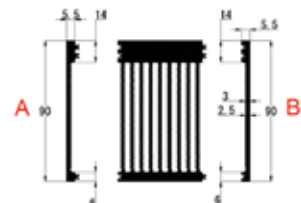

<b>Kg/mt</b>	0.87 Kg/mt
<b>L</b>	5.50 mm
<b>H</b>	90 mm
<b>Alloy</b>	6061

**CODE AE5.5\_125**

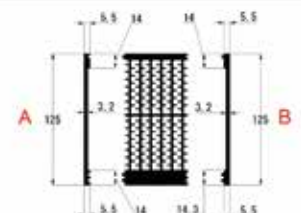

<b>Kg/mt</b>	1.37 Kg/mt
<b>L</b>	5.50 mm
<b>H</b>	125 mm
<b>Alloy</b>	6061

**CODE AE5.8\_77**

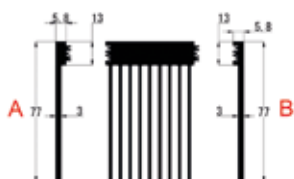

<b>Kg/mt</b>	0.75 Kg/mt
<b>L</b>	5.80 mm
<b>H</b>	77 mm
<b>Alloy</b>	6061

**CODE AE5.9\_100**



<b>Kg/mt</b>	0.69 Kg/mt
<b>L</b>	5.90 mm
<b>H</b>	100 mm
<b>Alloy</b>	6061

**CODE AE5\_41.50**



<b>Kg/mt</b>	0.29 Kg/mt
<b>L</b>	5 mm
<b>H</b>	41.5 mm
<b>Alloy</b>	6061

**CODE AE6.3\_77**

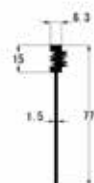

<b>Kg/mt</b>	0.50 Kg/mt
<b>L</b>	6.30 mm
<b>H</b>	77 mm
<b>Alloy</b>	6061

**CODE AE6\_90**



<b>Kg/mt</b>	0.68 Kg/mt
<b>L</b>	6 mm
<b>H</b>	90 mm
<b>Alloy</b>	6061

**CODE AE6\_125**

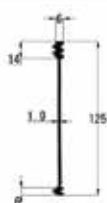

<b>Kg/mt</b>	0.86 Kg/mt
<b>L</b>	6 mm
<b>H</b>	125 mm
<b>Alloy</b>	6061

**CODE AE6\_57**



<b>Kg/mt</b>	0.51 Kg/mt
<b>L</b>	6 mm
<b>H</b>	57 mm
<b>Alloy</b>	6061

**CODE AE6\_62**

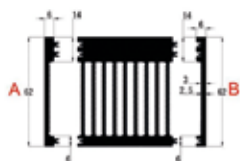

<b>Kg/mt</b>	0.44 Kg/mt
<b>L</b>	6 mm
<b>H</b>	62 mm
<b>Alloy</b>	6061

**CODE AE6\_75**



<b>Kg/mt</b>	0.51 Kg/mt
<b>L</b>	6 mm
<b>H</b>	75 mm
<b>Alloy</b>	6061

**CODE AE6\_117**

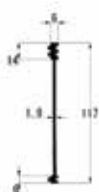

<b>Kg/mt</b>	0.81 Kg/mt
<b>L</b>	6 mm
<b>H</b>	117 mm
<b>Alloy</b>	6061

**CODE AE6\_127**



<b>Kg/mt</b>	0.96 Kg/mt
<b>L</b>	6 mm
<b>H</b>	127 mm
<b>Alloy</b>	6061

**CODE AE6\_90**



<b>Kg/mt</b>	0.77 Kg/mt
<b>L</b>	6 mm
<b>H</b>	90 mm
<b>Alloy</b>	6061

**CODE** AE6\_125



<b>Kg/mt</b>	0.98 Kg/mt
<b>L</b>	6 mm
<b>H</b>	125 mm
<b>Alloy</b>	6061

**CODE** DA7.6\_77.5

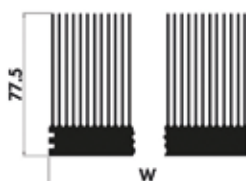

<b>L</b>	7.60 mm
<b>H</b>	77.50 mm
<b>Rth,F</b>	0.270 K/W
<b>Rth,N</b>	0.80 K/W
<b>Alloy</b>	1050

**CODE** DA7.6\_100

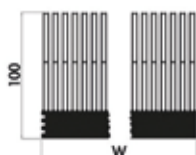

<b>L</b>	7.60 mm
<b>H</b>	100 mm
<b>Rth,F</b>	0.216 K/W
<b>Rth,N</b>	0.63 K/W
<b>Alloy</b>	6061

**CODE** DA8\_55



<b>L</b>	8 mm
<b>H</b>	55 mm
<b>Rth,F</b>	0.360 K/W
<b>Rth,N</b>	0.99 K/W
<b>Alloy</b>	1050

**CODE** DA8\_62

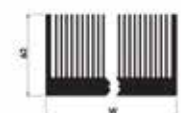
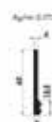

<b>L</b>	8 mm
<b>H</b>	62 mm
<b>Rth,F</b>	0.297 K/W
<b>Rth,N</b>	0.88 K/W
<b>Alloy</b>	1050

**CODE** AE9\_54



<b>Kg/mt</b>	0.63 Kg/mt
<b>L</b>	9 mm
<b>H</b>	54 mm
<b>Alloy</b>	6061

**CODE** AE9\_61.2



<b>Kg/mt</b>	0.67 Kg/mt
<b>L</b>	9 mm
<b>H</b>	61.2 mm
<b>Alloy</b>	6061

**CODE** DA9\_83.5

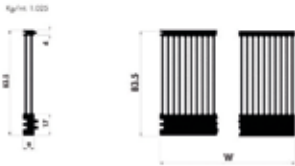

<b>L</b>	9 mm
<b>H</b>	83.50 mm
<b>Rth,F</b>	0.320 K/W
<b>Rth,N</b>	0.88 K/W
<b>Alloy</b>	1050

**CODE** DA10\_117

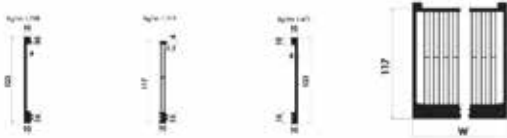

<b>L</b>	10 mm
<b>H</b>	0.70 K/W
<b>Rth,F</b>	0.240 K/W
<b>Rth,N</b>	117 mm
<b>Alloy</b>	1050

**CODE** DA10\_122



<b>L</b>	10 mm
<b>H</b>	122 mm
<b>Rth,F</b>	0.230 K/W
<b>Rth,N</b>	0.63 K/W
<b>Alloy</b>	1050

**CODE** AE10\_127

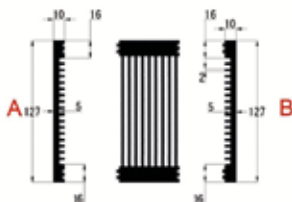

<b>Kg/mt</b>	2.52 Kg/mt
<b>L</b>	10 mm
<b>H</b>	127 mm
<b>Alloy</b>	6061

**CODE** DA10\_65

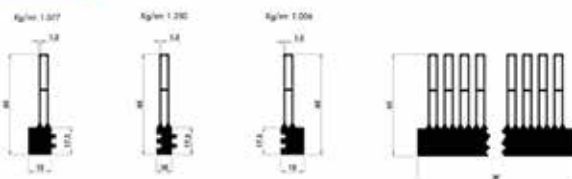

<b>L</b>	10 mm
<b>H</b>	65 mm
<b>Rth,F</b>	0.99 K/W
<b>Rth,N</b>	0.360 K/W
<b>Alloy</b>	1050

**CODE DA10\_71**



L	10 mm
H	71 mm
Rth,F	1.08 K/W
Rth,N	0.369 K/W
Alloy	1050

**CODE DA10\_75**

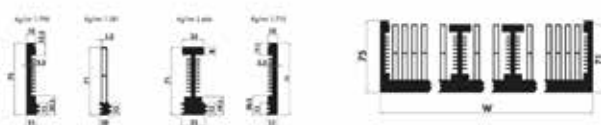

L	10 mm
H	75 mm
Rth,F	0.90 K/W
Rth,N	0.279 K/W
Alloy	1050

**CODE DA10\_78**

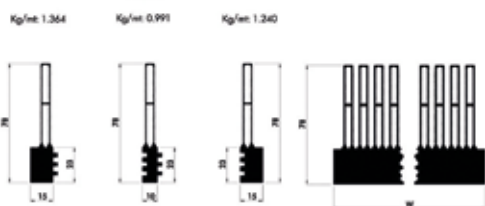

L	10 mm
H	78 mm
Rth,F	0.320 K/W
Rth,N	0.88 K/W
Alloy	1050

**CODE DA10\_81**



L	10 mm
H	81 mm
Rth,F	0.279 K/W
Rth,N	0.81 K/W
Alloy	1050

**CODE DA10\_85**



L	10 mm
H	85 mm
Rth,F	0.81 K/W
Rth,N	0.252 K/W
Alloy	1050

**CODE DA10\_90**



L	10 mm
H	90 mm
Rth,F	0.90 K/W
Rth,N	0.279 K/W
Alloy	1050



**CODE** DA10\_101

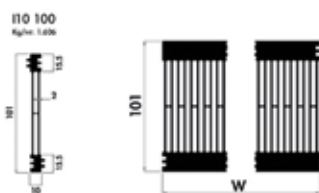

<b>L</b>	10 mm
<b>H</b>	101 mm
<b>Rth,F</b>	0.279 K/W
<b>Rth,N</b>	0.81 K/W
<b>Alloy</b>	1050

**CODE** DA10\_132.5

Kg/m: 1.434



<b>L</b>	10 mm
<b>H</b>	132.50 mm
<b>Rth,F</b>	0.210 K/W
<b>Rth,N</b>	0.56 K/W
<b>Alloy</b>	1050

**CODE** AE12.5\_125

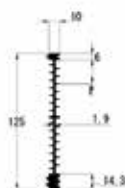

<b>Kg/mt</b>	1.38 Kg/mt
<b>L</b>	12.50 mm
<b>H</b>	125 mm
<b>Alloy</b>	6061

**CODE** AC12\_90



<b>Kg/mt</b>	1.40 Kg/mt
<b>L</b>	12 mm
<b>H</b>	90 mm
<b>Rth,F</b>	100 K/W

**CODE** AE12\_90



<b>Kg/mt</b>	1.40 Kg/mt
<b>L</b>	12 mm
<b>H</b>	90 mm
<b>Alloy</b>	6061

**CODE** AE12\_105



<b>Kg/mt</b>	1.53 Kg/mt
<b>L</b>	12 mm
<b>H</b>	105 mm
<b>Alloy</b>	6061

**CODE** AE12\_117



<b>Kg/mt</b>	1.64 Kg/mt
<b>L</b>	12 mm
<b>H</b>	117 mm
<b>Alloy</b>	6061

**CODE** AE12\_125



<b>Kg/mt</b>	1.76 Kg/mt
<b>L</b>	12 mm
<b>H</b>	125 mm
<b>Alloy</b>	6061

**CODE** DA12\_125

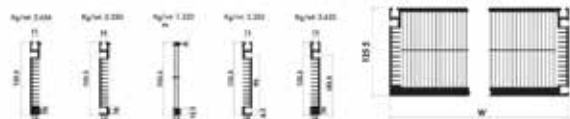

<b>L</b>	12 mm
<b>H</b>	125 mm
<b>Rth,F</b>	0.220 K/W
<b>Rth,N</b>	0.63 K/W
<b>Alloy</b>	1050

**CODE** DA12\_127



<b>L</b>	12 mm
<b>H</b>	127 mm
<b>Rth,F</b>	0.250 K/W
<b>Rth,N</b>	0.72 K/W
<b>Alloy</b>	1050

**CODE** AE13.79\_84

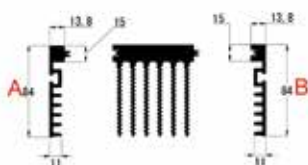

<b>Kg/mt</b>	1.52 Kg/mt
<b>L</b>	13.79 mm
<b>H</b>	84 mm
<b>Alloy</b>	6061

**CODE** DA15\_118



<b>L</b>	15 mm
<b>H</b>	118 mm
<b>Rth,F</b>	0.81 K/W
<b>Rth,N</b>	0.290 K/W
<b>Alloy</b>	1050

**CODE** A20\_41

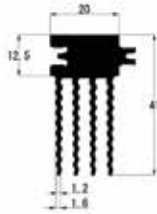

<b>Kg/mt</b>	1.08 Kg/mt
<b>L</b>	20 mm
<b>H</b>	41 mm
<b>Alloy</b>	6061

**CODE** AE25\_41

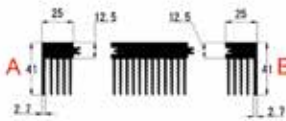

<b>Kg/mt</b>	1.52 Kg/mt
<b>L</b>	25 mm
<b>H</b>	41 mm
<b>Alloy</b>	6061

**CODE** AE37.24\_84

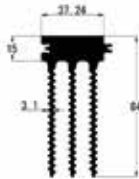

<b>Kg/mt</b>	3.16 Kg/mt
<b>L</b>	37.24 mm
<b>H</b>	84 mm
<b>Alloy</b>	6061

**CODE** DA50\_62



<b>L</b>	50 mm
<b>H</b>	62 mm
<b>Rth,F</b>	0.220 K/W
<b>Rth,N</b>	0.63 K/W
<b>Alloy</b>	1050

**CODE** DE84\_6.6

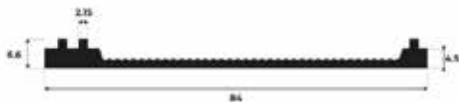

<b>Kg/mt</b>	0.54
<b>L</b>	84 mm
<b>H</b>	6.6 mm
<b>Alloy</b>	6061

**CODE** DE84\_7.1

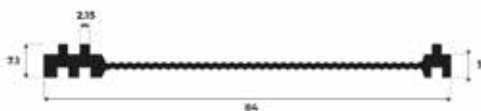

<b>Kg/mt</b>	0.97 Kg/mt
<b>L</b>	84 mm
<b>H</b>	7.1 mm
<b>Alloy</b>	6061

**CODE** DA95\_70.5



L	95 mm
H	70.50 mm
Rth,F	0.480 K/W
Rth,N	1.40 K/W
Alloy	1050

**CODE** AC100,5-12,5



Kg/mt	1.3 Kg/mt
L	100,5 mm
H	12,5 mm
Alloy	6060

**CODE** DE125\_10.1

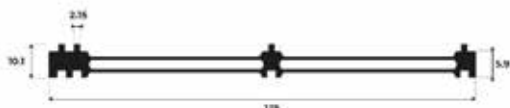

Kg/mt	1.35 Kg/mt
L	125 mm
H	10.1 mm
Alloy	6061

**CODE** DE140\_125

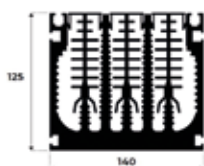

Kg/mt	22.9 Kg/mt
L	140 mm
H	125 mm
Rth,F	0.18 K/W
Rth,N	0.81 K/W
Alloy	6061

**CODE** DE150\_125

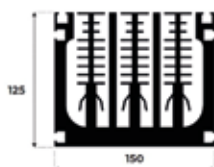

Kg/mt	23.77 Kg/mt
L	150 mm
H	125 mm
Rth,F	0.128 K/W
Rth,N	0.38 K/W
Alloy	6061

**CODE** AE190.5\_83

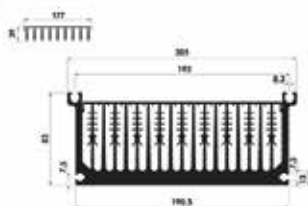

Kg/mt	18.87 Kg/mt
L	190.50 mm
H	83 mm
Rth,F	0.260 K/W
Rth,N	0.72 K/W
Alloy	6061

**CODE** DE200\_125\_B

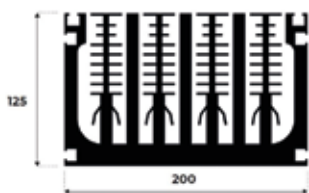

<b>Kg/mt</b>	30.8 Kg/mt
<b>L</b>	200 mm
<b>H</b>	125 mm
<b>Rth,F</b>	0.088 K/W
<b>Rth,N</b>	0.26 K/W
<b>Alloy</b>	6061

**CODE** DE200\_125\_A

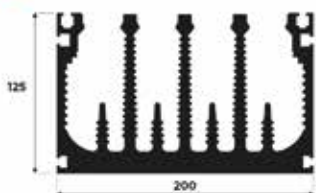

<b>Kg/mt</b>	24.440 Kg/mt
<b>L</b>	200 mm
<b>H</b>	125 mm
<b>Rth,F</b>	0.088 K/W
<b>Rth,N</b>	0.26 K/W
<b>Alloy</b>	6061

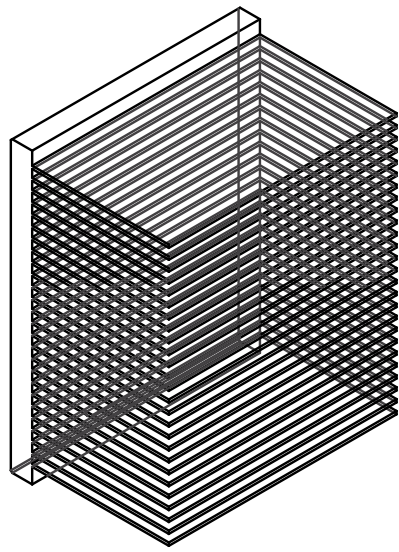
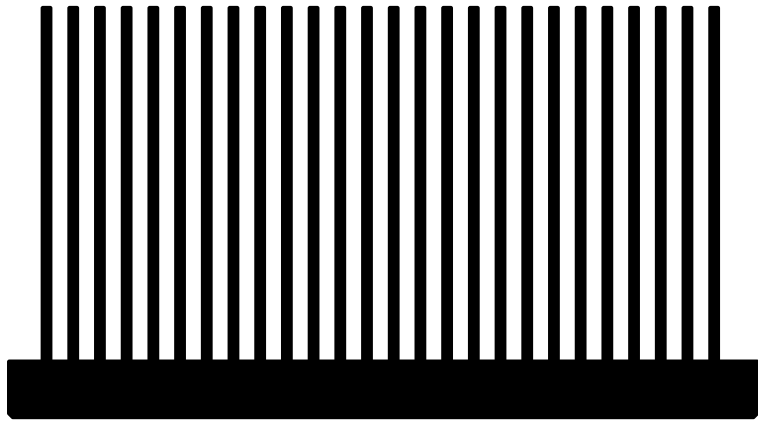

# HEATSINK - PLUS

## TECHNOLOGY

---

# Tecnologia HEAT PLUS

La tecnologia Heat Plus rivoluziona il settore della dissipazione termica, garantendo un raffreddamento efficiente per una vasta gamma di componenti elettronici. Grazie a un design innovativo e materiali di alta qualità, questa soluzione tecnologica assicura prestazioni superiori, mantenendo stabile la temperatura degli apparecchi elettronici anche nelle condizioni più estreme.

## Mechanical properties

	Tensile strength	0,2 Proof Stress	Elongation	Hardness	Module of elasticity
Aluminum EN AW-1050A	80 N/mm <sup>2</sup>	35 N/mm <sup>2</sup>	38%	21 HB	65 kN/mm <sup>2</sup>
Aluminum EN AW-6101B	120 N/mm <sup>2</sup>	70 N/mm <sup>2</sup>	9%	25 HB	69 kN/mm <sup>2</sup>
Copper	210 N/mm <sup>2</sup>	120 N/mm <sup>2</sup>	45%	45 HV	110 kN/mm <sup>2</sup>

## Chemical Composition

	Si	Fe	Mn	Mg	Cu	Zn	Ti	Altri	Al
Aluminum EN AW-1050A	0,25	0,40	0,05	0,05	0,05	0,07	0,05	0,03 (each)	99,5 (min)
Aluminum EN AW-6101B	0,30-0,60	0,10-0,30	0,05	0,35-0,60	0,05	0,1	-	0,03 (each)	98,2 (max)
Copper	-	-	-	-	99,95 (min)	-	-	0,05 (tot)	

## Physical properties

Density	Thermal conductivity	Electrical conductivity	Linear thermal expansion coeff.
2,70 Kg/dm <sup>3</sup>	229 W/mK	35,4 m/Ωmm <sup>2</sup>	23,6 10 <sup>-6</sup> 1/K
2,70 Kg/dm <sup>3</sup>	219 W/mK	32,6 m/Ωmm <sup>2</sup>	23,4 10 <sup>-6</sup> 1/K
8,93 Kg/dm <sup>3</sup>	390 W/mK	57,0 m/Ωmm <sup>2</sup>	16,8 10 <sup>-6</sup> 1/K

## Application Properties

Machinability	Weldability	Corrosion Resistance	Formability	Surface Treatment
Media	Buona	Ottima	Buona	Buona
Buona	Ottima	Ottima	Media	Buona
Media	Buona	Buona	Buona	Buona

**TECHNOLOGY**

**HeatPlus**

Heatsink Width (W)	max 1000 mm <small>(without welding)</small>
Heatsink Length (L)	max 1300 mm
Base Thickness (BT)	8 ÷ 50 mm
Fin Height (FH)	max 190 mm
Fin Thickness (FT)	1 ÷ 3 mm
Fins Distance (FD)	min 2 mm
Aspect Ratio (FH/FD)	max 95:1
Tolerances on dim. & machining	ISO 2768-mk
Material	EN AW-1050A - EN AW-6101B - Copper



**TECHNOLOGY**

**UltraHeat**

Heatsink Width (W)	max 1000 mm <small>(without welding)</small>
Heatsink Length (L)	max 1300 mm
Base Thickness (BT)	8 ÷ 50 mm
Fin Height (FH)	max 190 mm
Fin Thickness (FT)	0,8 / 4 mm
Fins Distance (FD)	min 1 mm
Aspect Ratio (FH/FD)	max 95:1
Tolerances on dim. & machining	ISO 2768-mk
Material	EN AW-1050A - EN AW-6101B - Copper



**TECHNOLOGY**

**DoubleHeat**

Heatsink Width (W)	max 1000 mm <small>(without welding)</small>
Heatsink Length (L)	max 1300 mm
Base Thickness (BT)	8 ÷ 50 mm
Fin Height (FH)	max 190 mm
Fin Thickness (FT)	0,8 / 4 mm
Fins Distance (FD)	min 2 mm
Aspect Ratio (FH/FD)	max 95:1
Tolerances on dim. & machining	ISO 2768-mk
Material	EN AW-1050A - EN AW-6101B - Copper





**CODE** HA100\_40

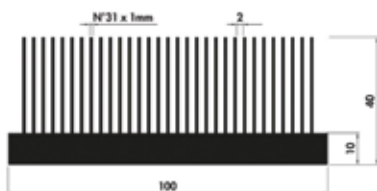

<b>Kg/mt</b>	5.21 Kg/mt
<b>L</b>	100 mm
<b>H</b>	40 mm
<b>Alloy</b>	6061

**CODE** HA150\_60

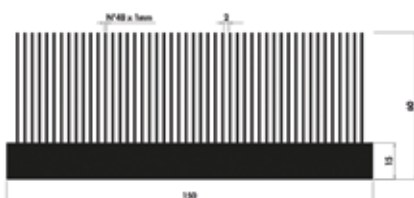

<b>Kg/mt</b>	11.18 Kg/mt
<b>L</b>	150 mm
<b>H</b>	60 mm
<b>Alloy</b>	6061

**CODE** HA200\_70

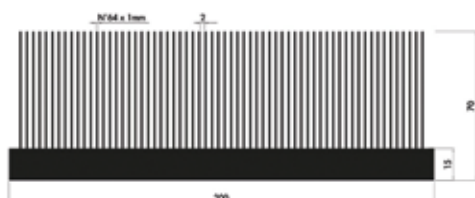

<b>Kg/mt</b>	17.60 Kg/mt
<b>L</b>	200 mm
<b>H</b>	70 mm
<b>Alloy</b>	6061

**CODE** HA250\_85

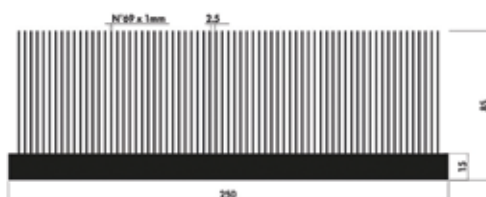

<b>L</b>	250 mm
<b>H</b>	85 mm
<b>Alloy</b>	6061

EXTRUDED  
TECHNOLOGY

WELDING  
TECHNOLOGY

ASSEMBLED  
TECHNOLOGY

HEATPLUS  
TECHNOLOGY

COLDPLATE  
TECHNOLOGY

PV  
PROFILES

**CODE HA300\_85**

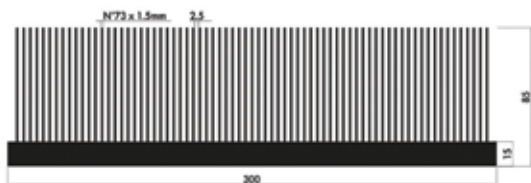

<b>Kg/mt</b>	32.85 Kg/mt
<b>L</b>	300 mm
<b>H</b>	85 mm
<b>Alloy</b>	6061

**CODE HA300\_135**

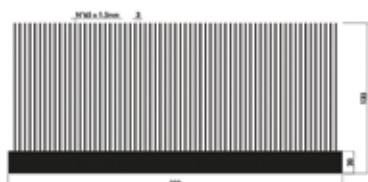

<b>Kg/mt</b>	46.47 Kg/mt
<b>L</b>	300 mm
<b>H</b>	135 mm
<b>Alloy</b>	6061

**CODE HA350\_75**

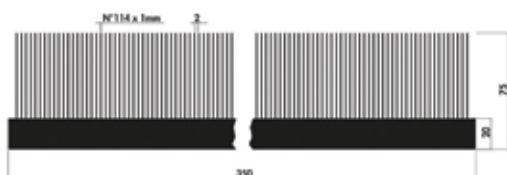

<b>L</b>	350 mm
<b>H</b>	75 mm
<b>Alloy</b>	6061

**CODE HA400\_85**

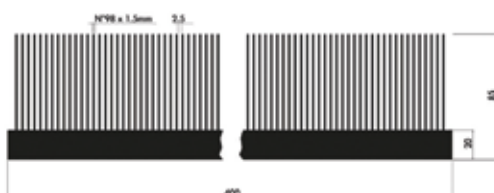

<b>L</b>	400 mm
<b>H</b>	85 mm
<b>Alloy</b>	6061

**CODE** HA500\_100

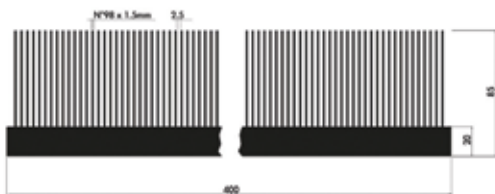

<b>L</b>	500 mm
<b>H</b>	100 mm
<b>Alloy</b>	6061

**CODE** HA600\_85

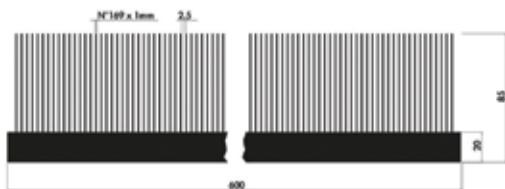

<b>Kg/mt</b>	62.02 Kg/mt
<b>L</b>	600 mm
<b>H</b>	85 mm
<b>Alloy</b>	6061

**CODE** HA700\_100

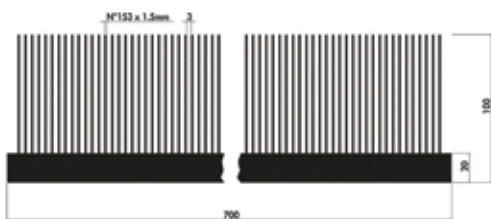

<b>Kg/mt</b>	87.37 Kg/mt
<b>L</b>	700 mm
<b>H</b>	100 mm
<b>Alloy</b>	6061

**CODE** HA800\_135

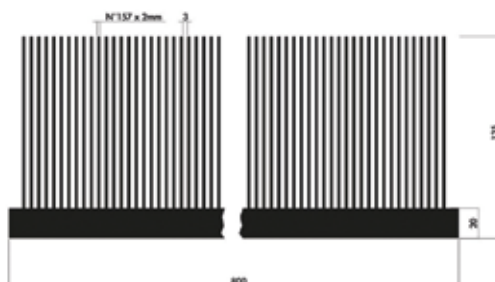

<b>Kg/mt</b>	140.70 Kg/mt
<b>L</b>	800 mm
<b>H</b>	135 mm
<b>Alloy</b>	6061



# **WATER** **TECHNOLOGY**

---

**CODE** DA90\_20

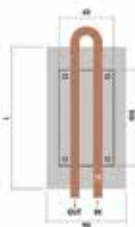

<b>L</b>	90 mm
<b>H</b>	20 mm
<b>Alloy</b>	6060

**CODE** DA180\_20

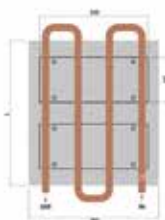

<b>L</b>	180 mm
<b>H</b>	20 mm
<b>Alloy</b>	6060

**CODE** DA360\_20

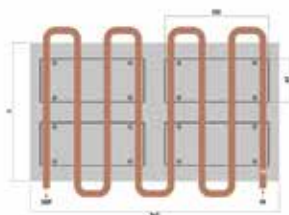

<b>L</b>	360 mm
<b>H</b>	20 mm
<b>Alloy</b>	6060

**CODE** DA360\_20

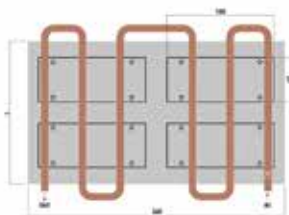

<b>L</b>	360 mm
<b>H</b>	20 mm
<b>Alloy</b>	6060

EXTRUDED  
TECHNOLOGY

WELDING  
TECHNOLOGY

ASSEMBLED  
TECHNOLOGY

HEATPLUS  
TECHNOLOGY

COLDPLATE  
TECHNOLOGY

PV  
PROFILES

The logo for MGSKIVED TECHNOLOGY is positioned in the bottom-left corner of a dark grey background. It features the word "MGSKIVED" in a large, bold, white sans-serif font, with the word "TECHNOLOGY" in a smaller, bold, red sans-serif font directly below it. A thin red horizontal line is located below the word "TECHNOLOGY". The overall design is minimalist and modern, with a red and white color palette.

**MGSKIVED**  
**TECHNOLOGY**

---



## NEW DISSIPATION TECHNOLOGY

# MGSKIVED HEATSINKS

MGSKIVED technology is used when fins intensity cannot be achieved through extrusion technology. We can use both copper and aluminum.

Today, this technology allows us to overcome the limitations of the thickness and length ratio of conventional heat sinks, and our machines can produce high-density, very high-efficiency heat sinks. We can create tall and extremely thin fin-heat sinks with a long structure thanks to our dedicated beveling machines, using high-precision beveling cutting technology.

Our machines use a single block of material such as copper or aluminum. The fins and base become a “whole”.

Therefore the efficiency of the heat sink with extended fins is up to two times higher than the traditional heat sink.

Thermal conductivity efficiency can reach 100% of the profile material. This technology can be applied in the photovoltaic industry, electric vehicles, inverters, communication products, LED lights.

### General Specifications

Heat Sink Width (W)	max 3000 mm
Heat Sink Length (L)	max 580 mm
Heat Sink Height (H)	max 120 mm
Fin Thickness (FT)	0,3+1 mm
Fin Pitch (FD)	min 1,5 mm
Material	Aluminum, Copper



**PV**  
**PROFILES**

---



**CODE SC-467-90**

Central support kit



**CODE PF-REGO-50**

Universal standard end clamp H 29 mm to 50 mm

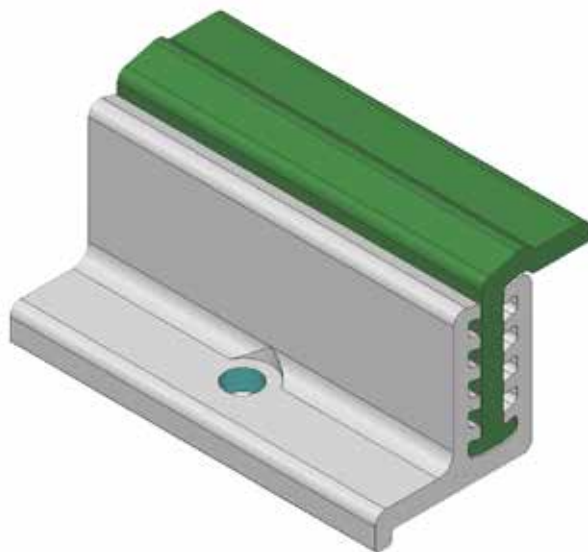
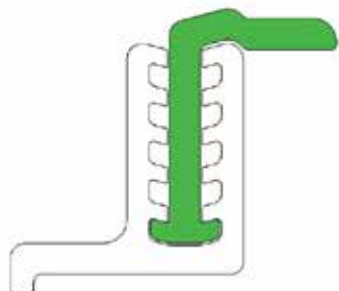

**CODE TB 05608**

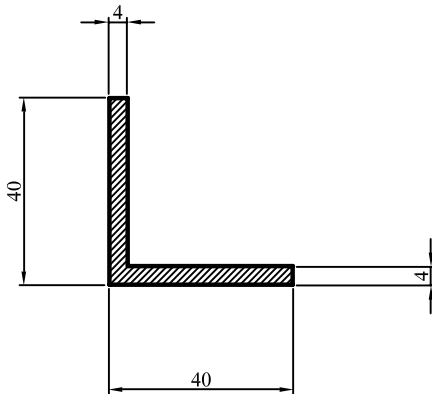

**CODE TB 09870**

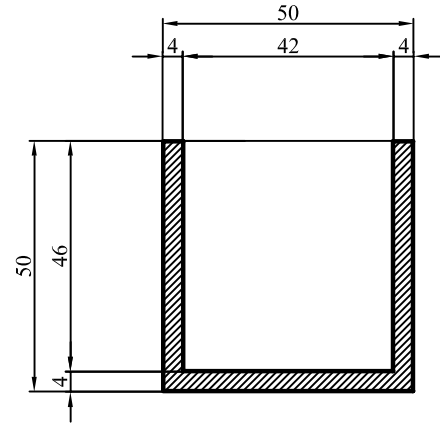

**CODE TB 39061**

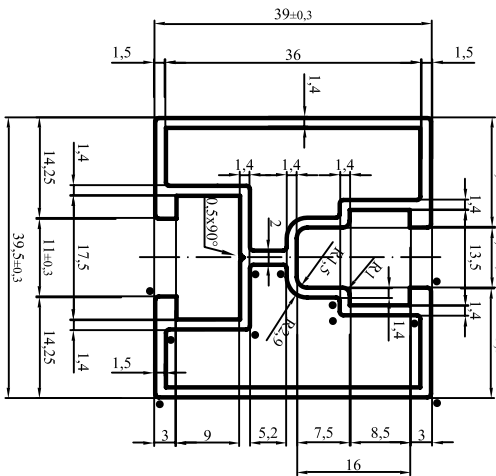

**CODE TB 39062**

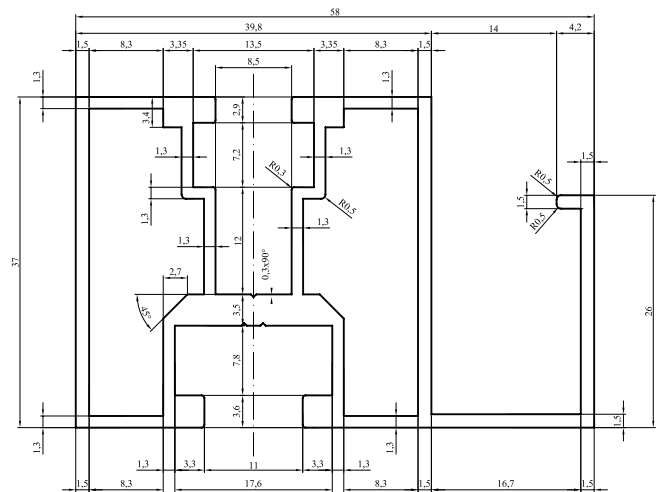

**CODE TB 40381**

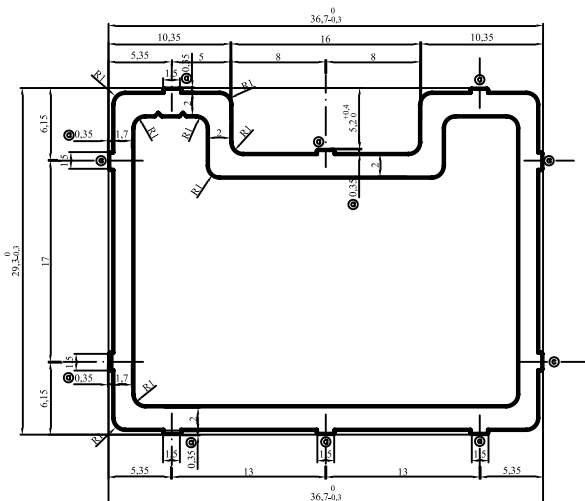

**CODE TB 40669**

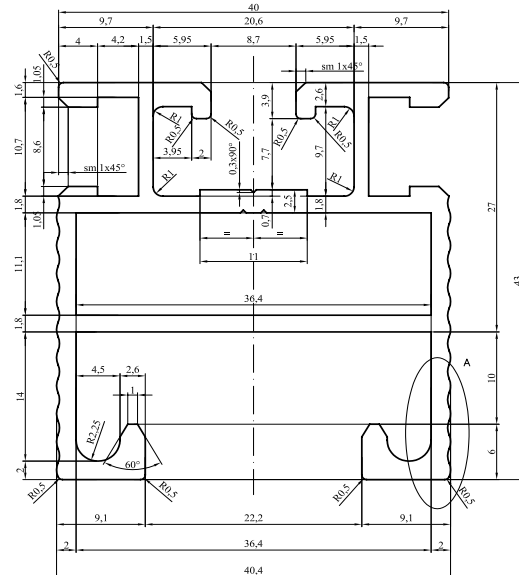

**CODE TB 40692**

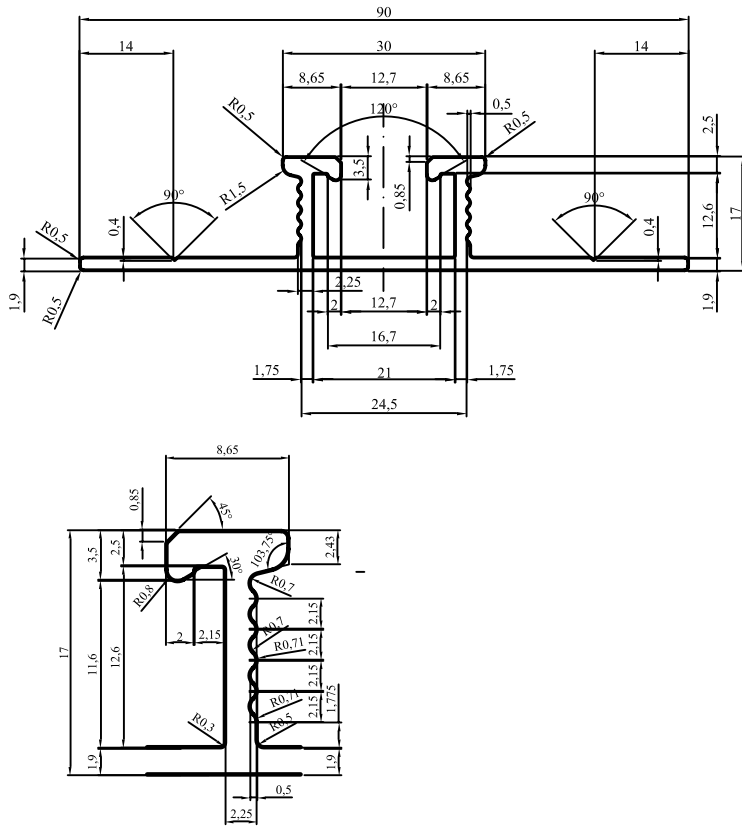

**CODE TB 40838**

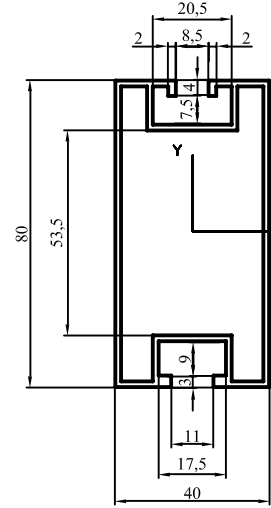

**CODE TB 40905**

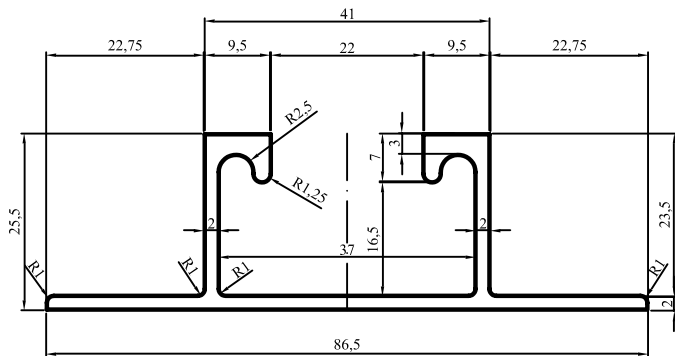

**CODE TB 40922**

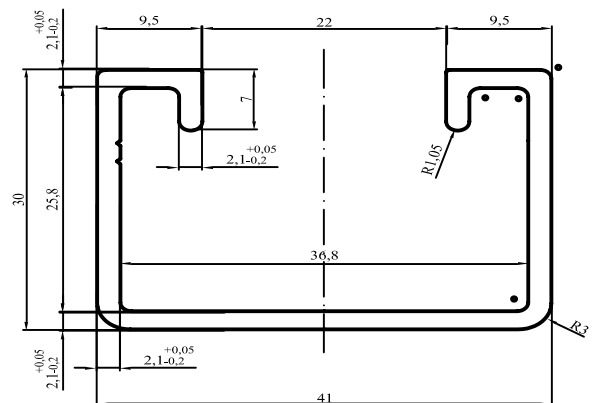



**CODE TB 40985**

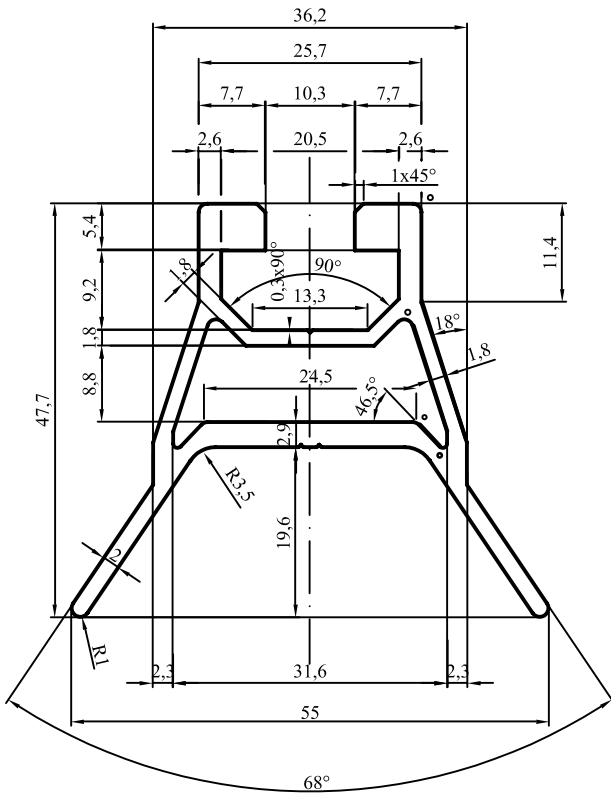

**CODE TB 41025**

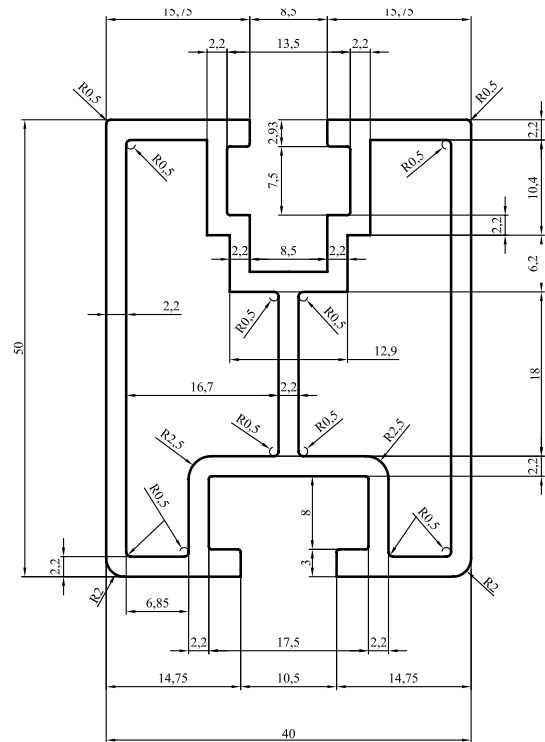

**CODE TB 41026**

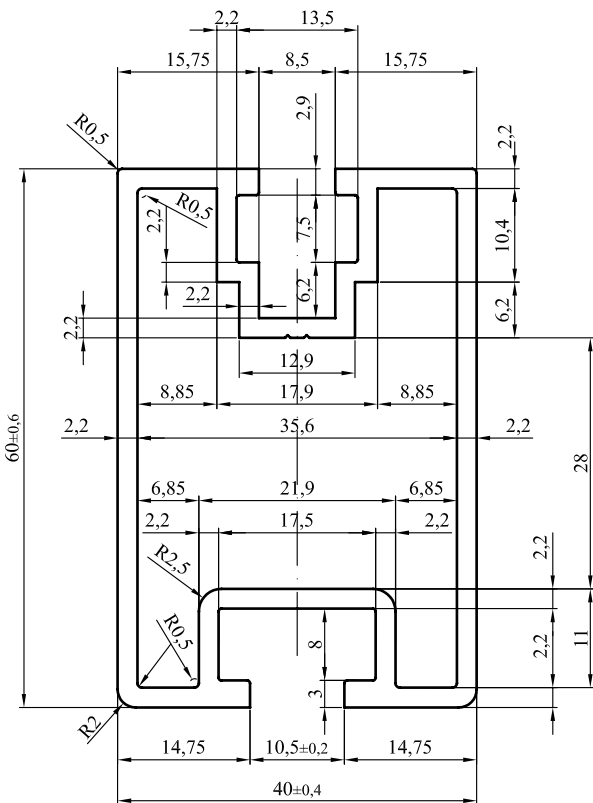

**CODE TB 41092**

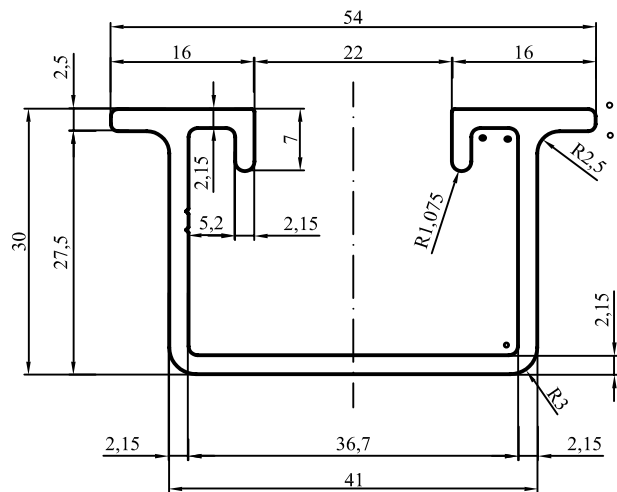

**CODE TB 41174**

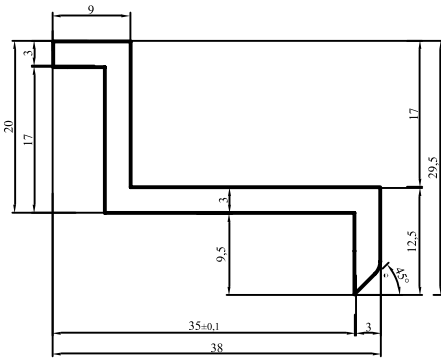

**CODE TB 41176**

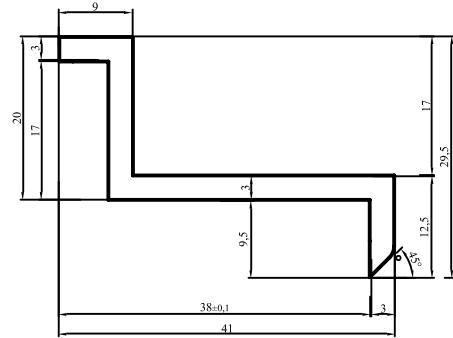

**CODE TB 41187**

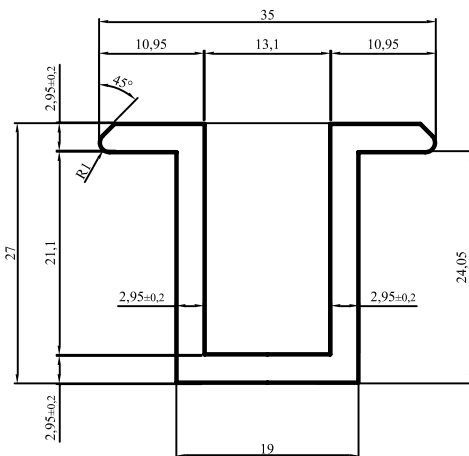

**CODE TB 41367**

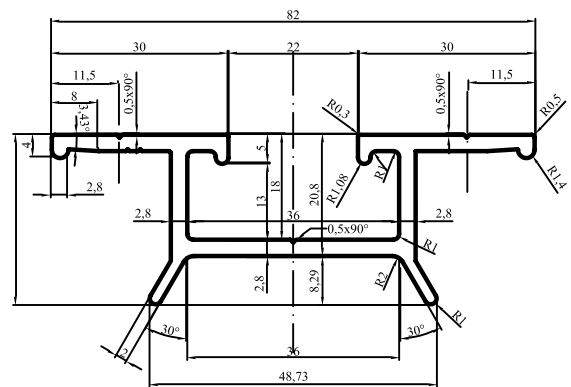

**CODE TB 41187**

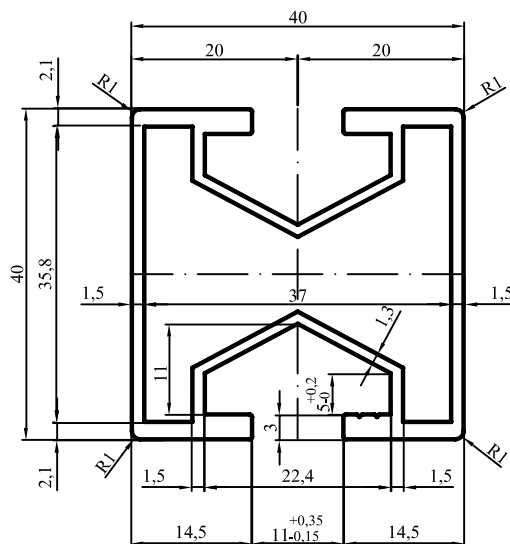

**CODE TB 41539**

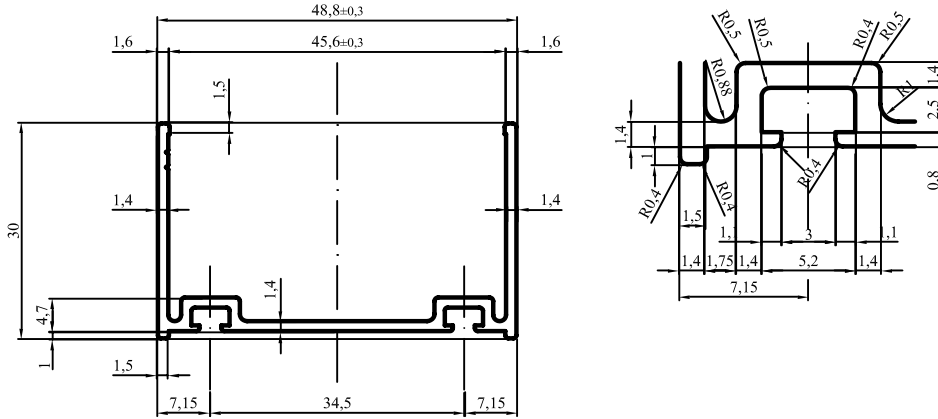

**CODE TB 41590**

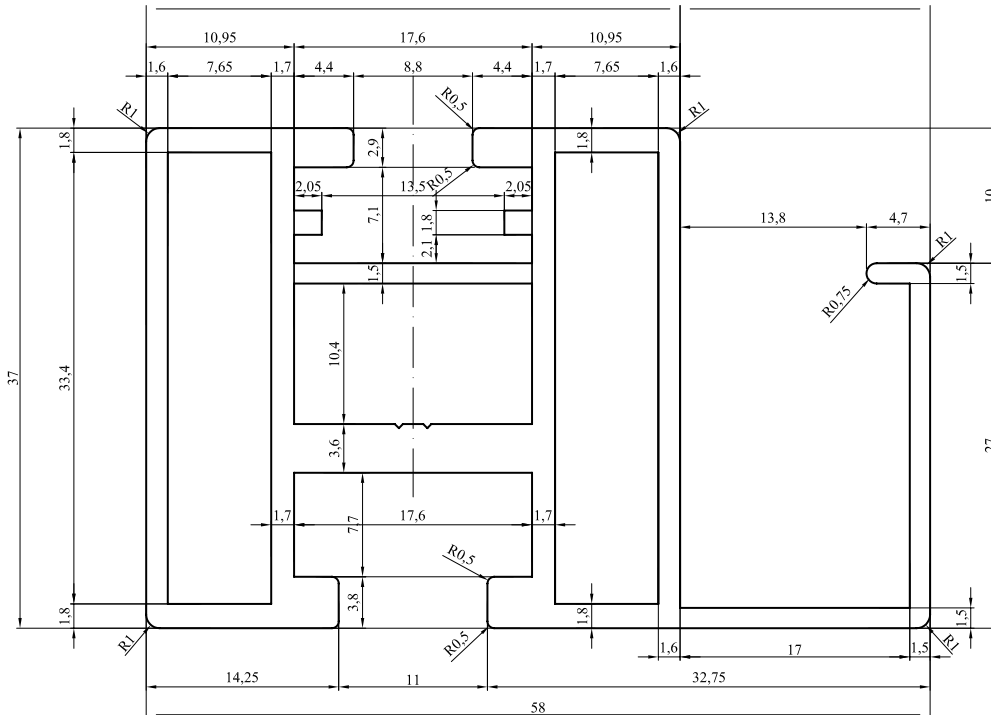

**CODE TB 41591**

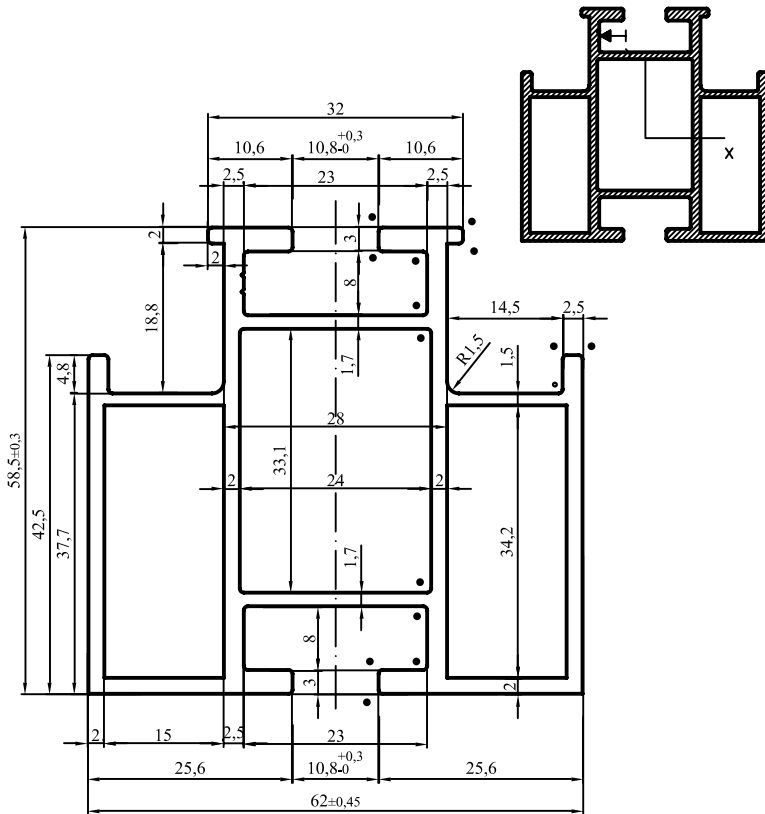

**CODE TB 41969**

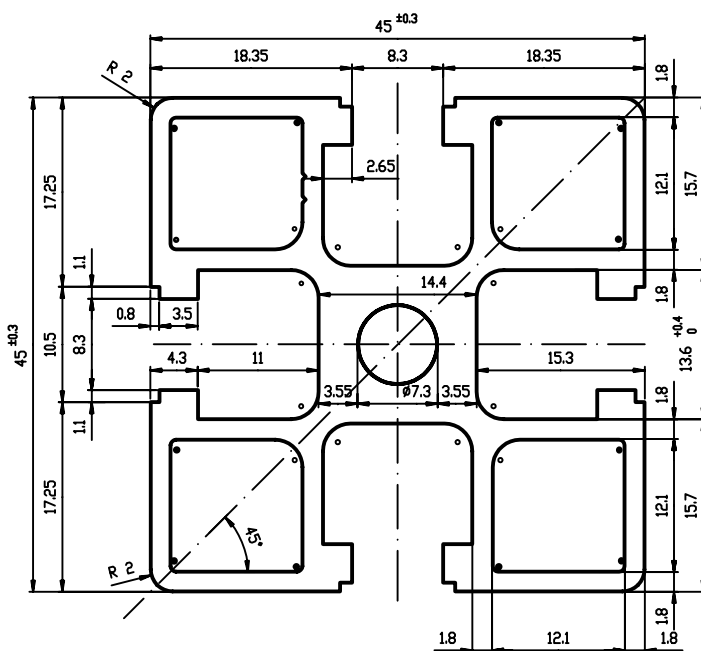



**CODE TB 41970**

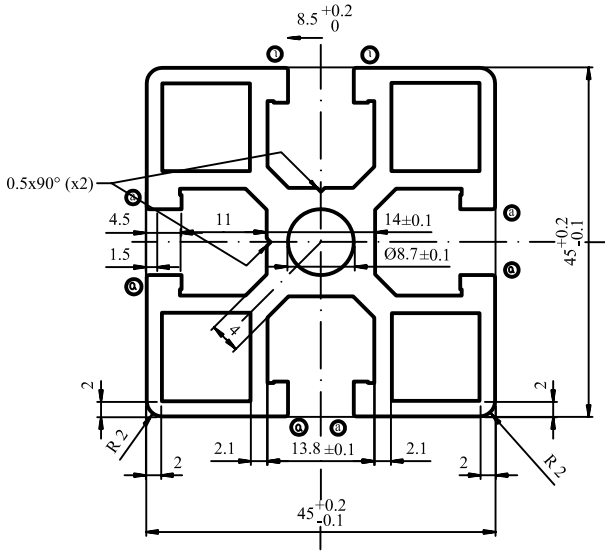

**CODE TB 41971**

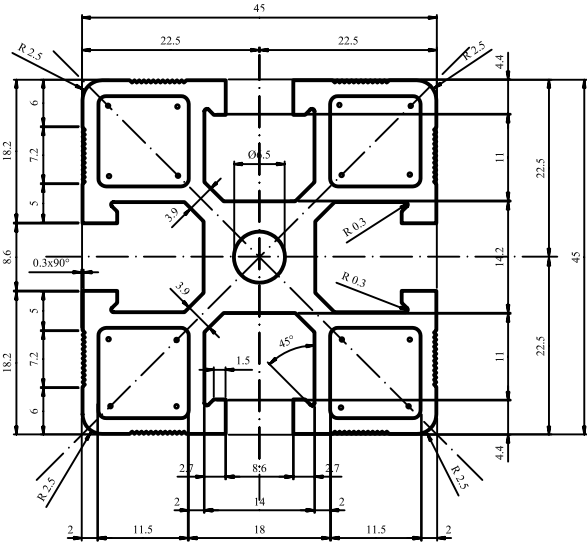

**CODE TB 41972**

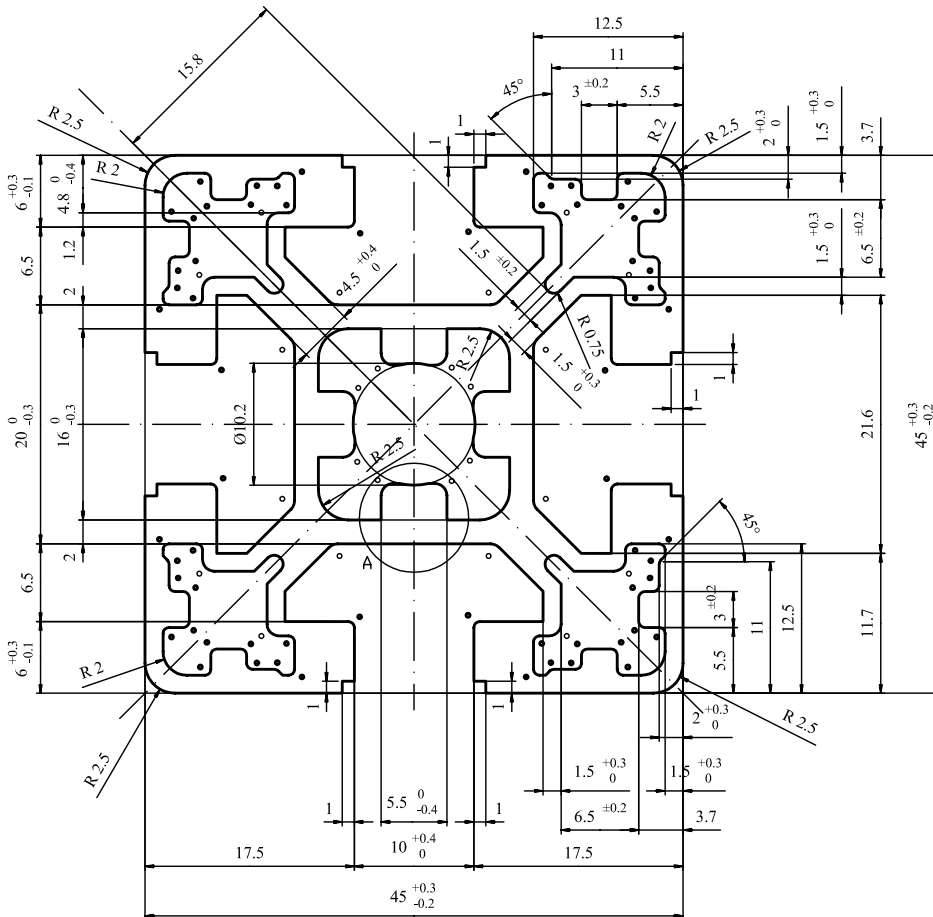

**CODE TB 41173**

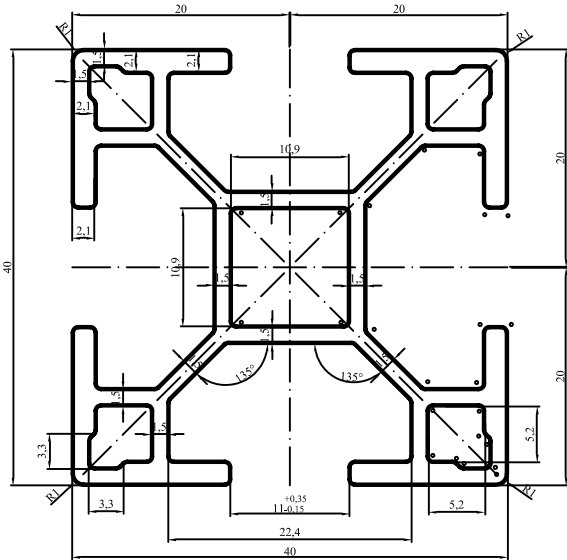

**CODE TB 41174**

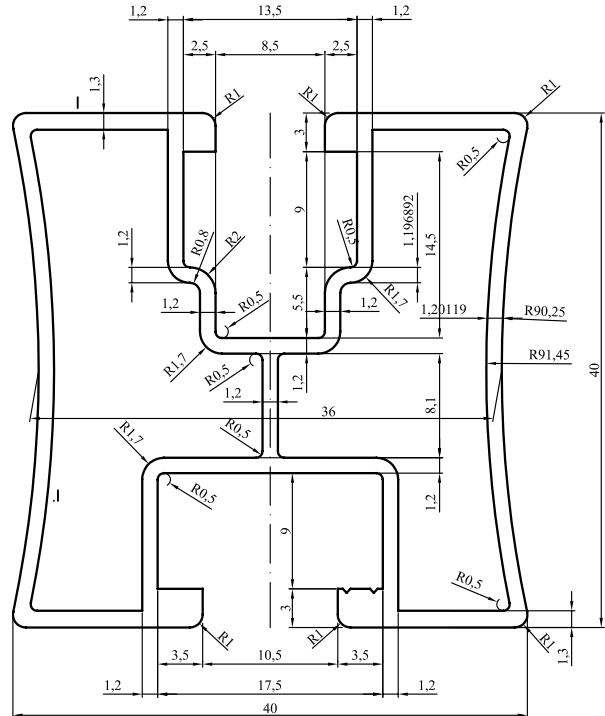

**CODE TB 41975**

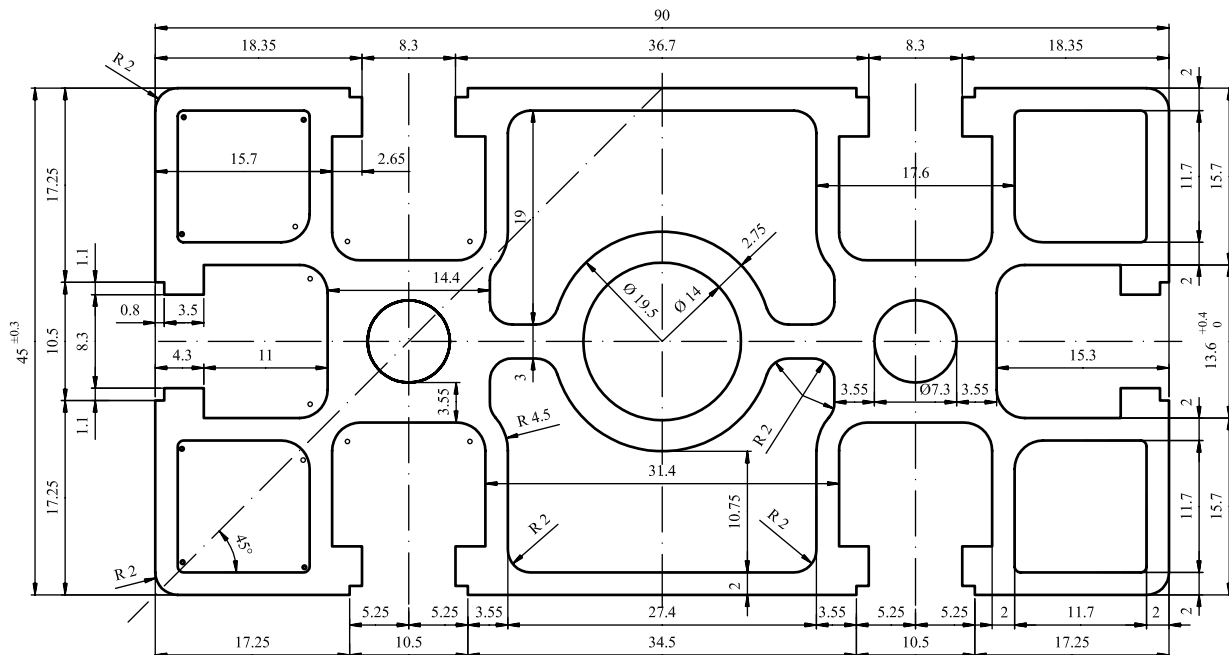
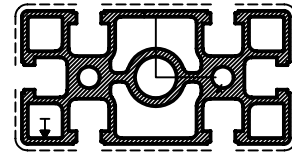

CODE **TB 41977**

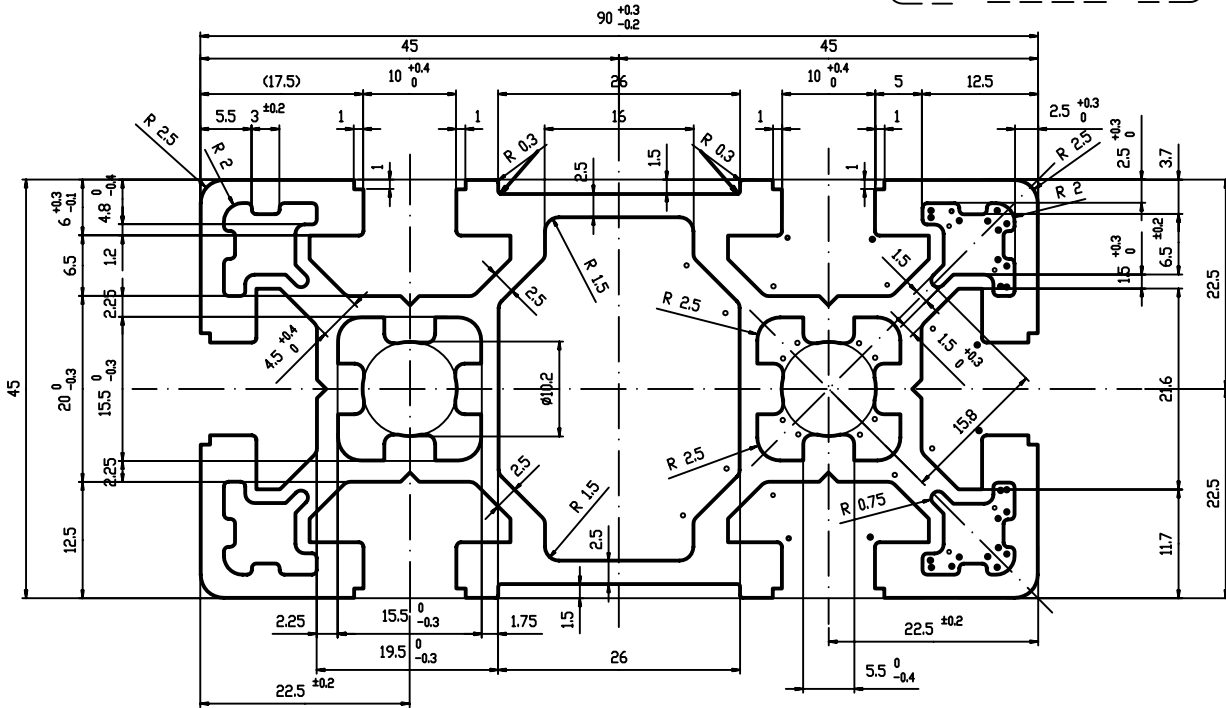
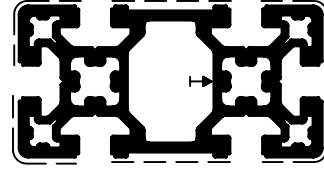

CODE **TB 41978**

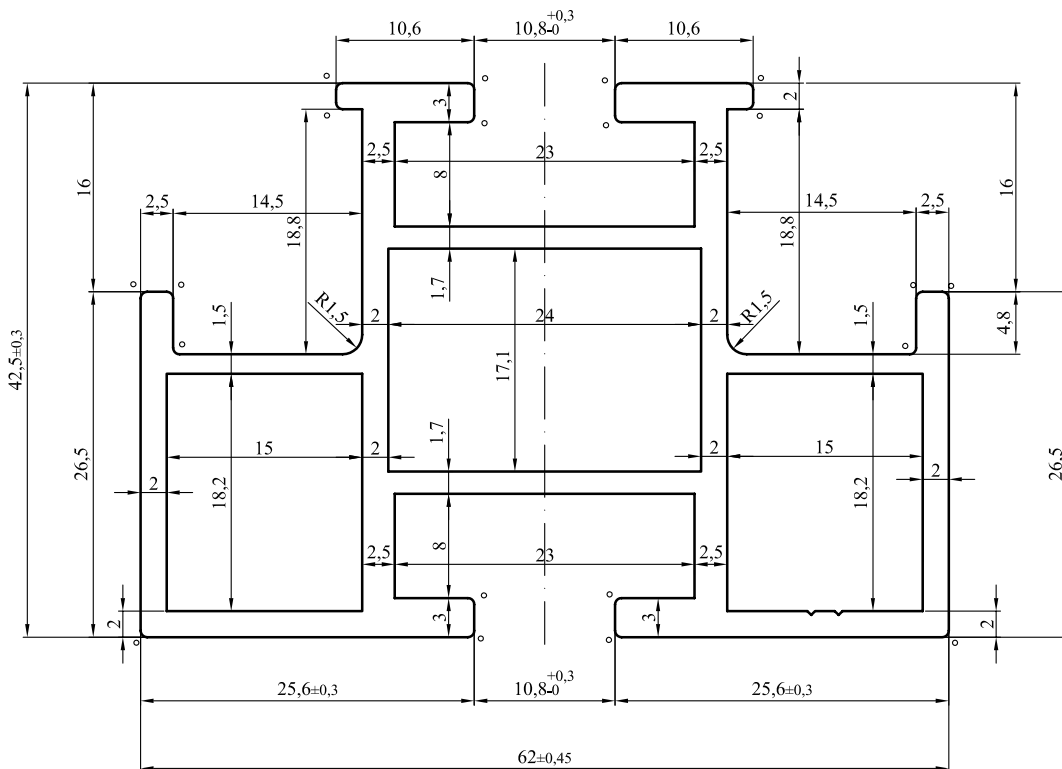

**CODE TB 41979**

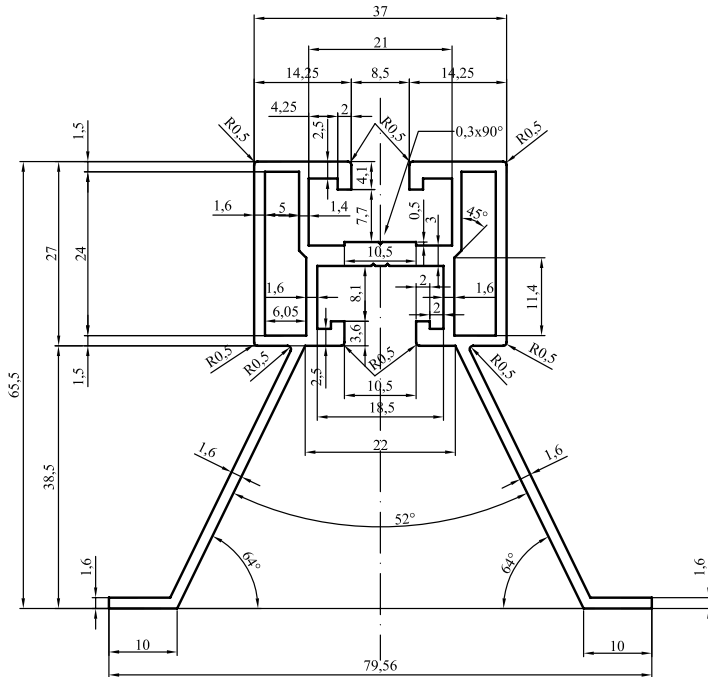

**CODE TB 41980**

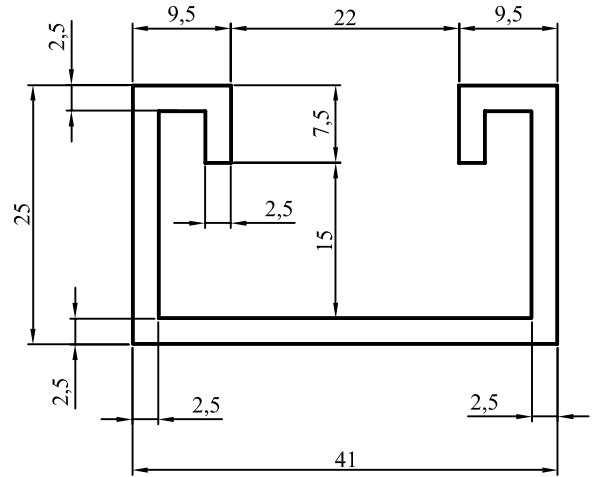

**CODE TB 41990**

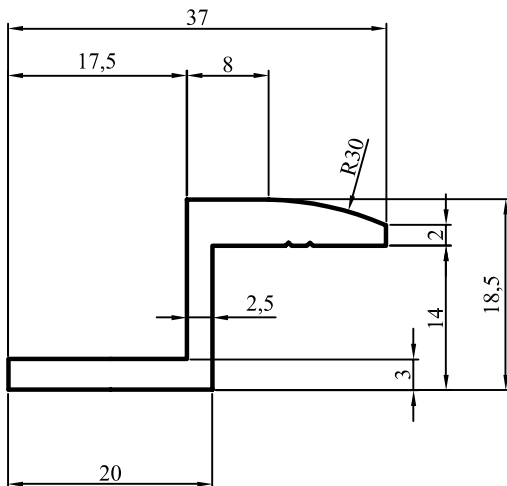

**CODE TB 41994**

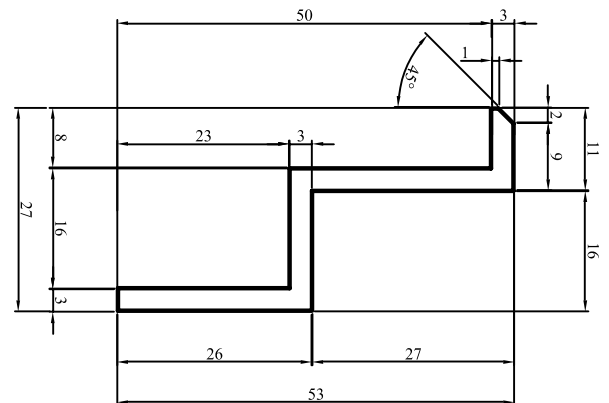



# Processes & MACHINING

*MG ITALY carries out countless processes in order to obtain finished products of the highest quality*

---

- ◆ Cut
- ◆ CNC Technology
- ◆ Die Casting
- ◆ Surface treatments
- ◆ Assemblies



# Processes



## CUT

MG has a constantly updated fleet of machines and has over 7 systems dedicated solely to cutting operations. Covering a processing range from diameter 6mm to 200mm with a thickness of a few tenths up to the solid. In addition to round bars, we cut all types of shapes.

Several plants perform operations such as wire brush deburring (brushing), tap/die chamfering and rolling, threading, boring, turning, tapering and washing in line.

The materials we commonly work are carbon steel (iron), aluminum and its alloys (6060, ergal, etc.), copper, brass and stainless steel in various alloys (AISI 304 – AISI 316 – INCONEL – DUPLEX – SUPER DUPLEX etc.).

Thanks to the very modern machinery we are able to make cuts of various degrees, according to the customer's needs.



Wheel Cut



Band cut



## SURFACE TREATMENTS

Within its headquarters, the company has machinery for: metal burnishing, surface sandblasting, metal chrome plating, metal galvanizing, detail polishing.



Painting



Silk printing



## DIE-CASTING



Die casting



Sand casting



## CNC TECHNOLOGY

With a fleet of over 15 high-level machining centers, MG proposes itself as prime contractor for carrying out mechanical machining to customer drawings, guaranteeing the production of high precision parts with limited times and costs.

All the CNC machines always work manned by assigned personnel who are exclusively responsible for the good execution and dimensional control of the product they are making.

To make this way of working possible, the department heads supervise the production cycle, while other qualified personnel carry out some necessary and fundamental operations.



Milling



Turning



Laser cutting



Punching



Bending



## ASSEMBLY

To complete our mechanical processes, thanks to the know-how and experience acquired, our company is now specialized in the construction, assembly and assembly of groups for industrial plants and machinery.

We also carry out assembly of groups of equipment, carried out internally following the specific requests, guaranteeing care, attention and quality that our major customers recognize us after years of collaboration.



Mechanical assembly



Welding

# Notes





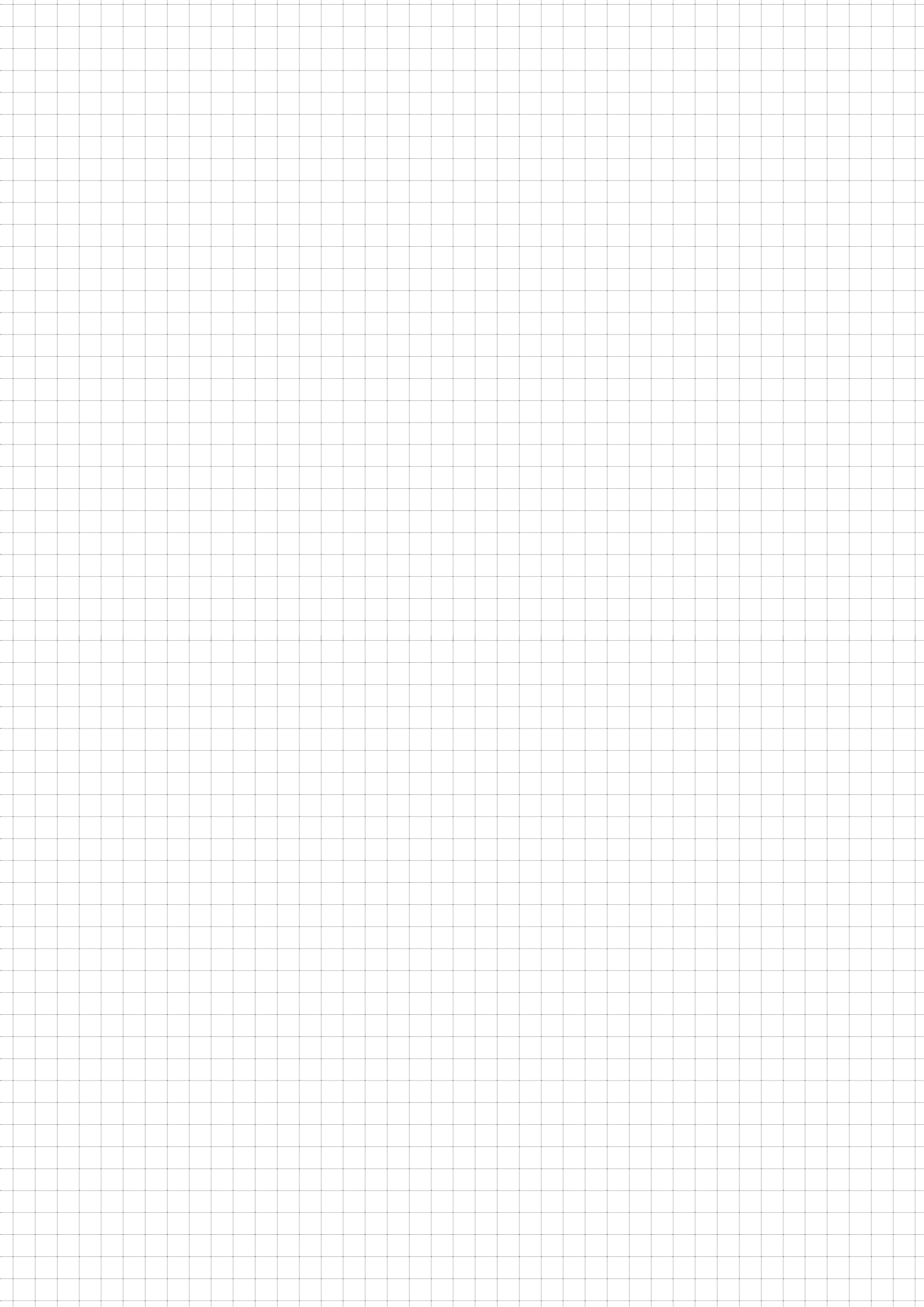

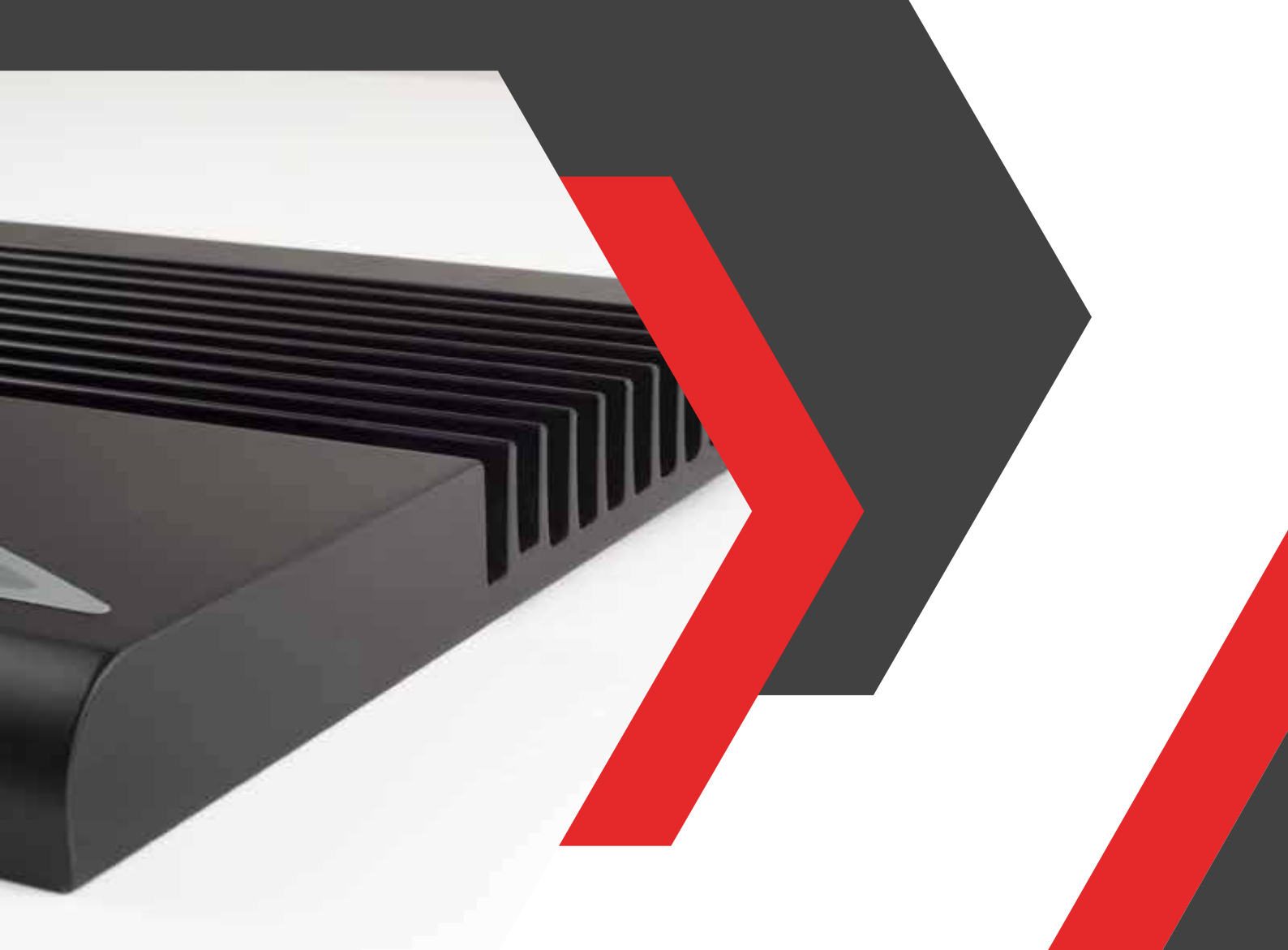

**MG ITALY**

YOUR PARTNER IN METALWORKING

MG philosophy:

***“Competition is not about what  
companies produce, but about what  
they are able to add to the product”***



YOUR PARTNER IN METALWORKING





**MG ITALY**  
YOUR PARTNER IN METALWORKING

Barcelona  
Spain  
Calle Perú,  
186 bis 08020

**MG ITALY**  
YOUR PARTNER IN METALWORKING

Arezzo  
Italy  
Via La Minierina, 10  
Loc. Meleto 52022  
Cavriglia

**MG ITALY**  
YOUR PARTNER IN METALWORKING

DACH-Region  
Germany  
Riedelsbach 61, 94089  
Neureichenau

#### GERMANY & AUSTRIA & SWITZERLAND:

Sales Representative DACH Region  
Mr. Uwe Rüttgers

✉ [uwe.ruettgers@mgitaly.it](mailto:uwe.ruettgers@mgitaly.it)

☎ +49 160 90 667 850

#### SPAIN & PORTUGAL

Sales Representative Region  
Mr. Carlos Bausà

✉ [carlos.bausa@mgitaly.it](mailto:carlos.bausa@mgitaly.it)

☎ +34 611 706 967

#### ITALY & FRANCE

Sales Representative Region  
Mr. Giovanni Arcidiacono

✉ [giovanni.arcidiacono@mgitaly.it](mailto:giovanni.arcidiacono@mgitaly.it)

☎ +39 055 91 23 830

## Customer service:

**MG ITALY**  
YOUR PARTNER IN METALWORKING

[www.mgitaly.it](http://www.mgitaly.it)



Phone: +39 055 91 23 830

Fax: 055 91 24 139



[Service-eu@mgitaly.it](mailto:Service-eu@mgitaly.it)



Via La Minierina n° 10  
52022 Cavriglia  
ITALIA ( AR )



MGItaly invites you to join its eco-friendly vision: enjoy our catalog in digital format and reduce the environmental impact.